

# Communications Receivers Manual

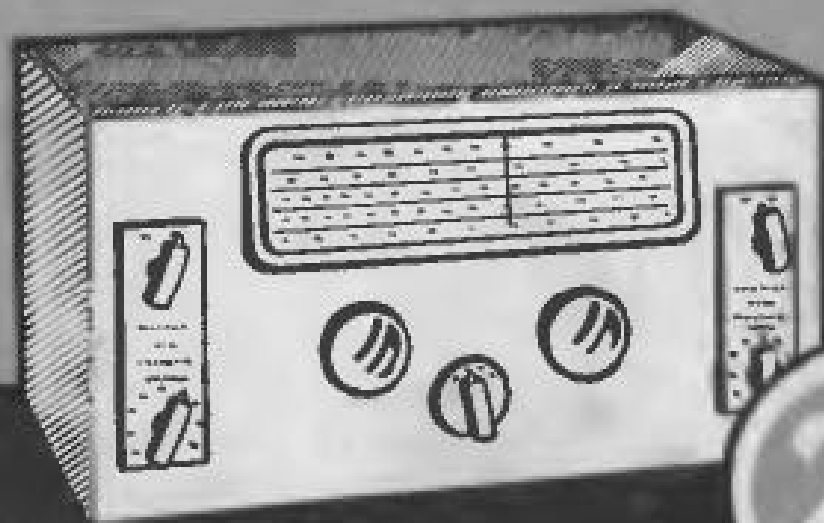

2/6

**POPULAR PHOTOGRAPHY,  
FLYING, PLASTICS,  
and the new PHOTOGRAPHY**

From the publishers of RADIO NEWS come these four superb magazines, each completely fulfilling, in its own sphere, the same essential purpose as RADIO NEWS. Informative to the highly skilled operator or technician, yet understandable and interesting to the amateur; intensely practical, yet never dry or stodge. Brilliantly written, copiously illustrated and beautifully produced, each magazine maintains the highest standards for which American magazines are famous.

Particulars of subscription rates and facilities on request.

**ZIFF DAVIS LIMITED,**  
GRAMPIANS BUILDING,  
WESTERN GATE, LONDON, W.6  
Telephone: SHEPHERDS BUSH 4794.

**AMPLIFIER KITS**

of outstanding performance. Using original circuits developed for high fidelity reproduction of records. These kits are only supplied by us and comprise ready drilled chassis complete with all components—down to nuts, bolts and solder.

3 & 7 watt models are available with a special amplifier designed for moving coil pick-ups

Blue prints are available of each model  
HFA1; 7 watt 8 valve Amplifier  
HFA2; 3 watt 5 valve Amplifier  
HFA3; 7 watt 8 valve Amplifier for Moving Coil pick-up.  
prints 2/6 e. ch.

Write for our lists of Amplifier kits, radio receiver kits, loudspeakers, pick-ups and associated equipment.

**CHARLES AMPLIFIERS LTD.**  
18, Palace Gate, Kensington, London, W.8  
Phone: WEStern 3150

**COMMUNICATIONS  
RECEIVERS' MANUAL**

by

**"RADIOTRICIAN"**

**RADIO NEWS**

foremost American Radio magazine, obtainable direct by post from America: the only sure way of receiving copies regularly.

RADIO NEWS unfolds, month by month, the complete story of radio research and development. Editorially and in presentation, printing and production, it maintains the highest American standards. Each issue contains from 136 to 160 pages of news, articles, pictures and advertisements, brilliantly written and illustrated.

Radio technicians, dealers, business and factory executives, radio specialists in the services, amateurs, "hams," officials, research specialists, constructors, all are fully catered for. The scope of RADIO NEWS, in all that matters, is complete.

For a modest sum, payable in advance, the postman will deliver a copy at the door every month.

Subscription orders may be placed through your Radio dealer or newsagent or, in case of difficulty, posted to us at the address below

**ZIFF DAVIS LIMITED,**  
GRAMPIANS BUILDING,  
WESTERN GATE, LONDON, W.6  
Telephone: SHEPHERDS BUSH 4794.



**BERNARDS (PUBLISHERS) LTD.**  
LONDON

First Published 1948

## CONTENTS

Chapter	Page
1. GENERAL CONSIDERATIONS ... ..	5
2. THE RECEIVER AND THE TRANSMITTER—Aerial Switching ...	11
3. PRACTICAL RECEIVING CIRCUITS — The R.F. Stage — The Frequency Converter—Coils for Amateur Band Coverage— The I.F. Amplifier—The Detector and A.V.C.—A.V.C. Con- trolled Stages—The "S" Meter—The Noise Limiter ...	16
4. THE CRYSTAL FILTER ... ..	32
5. THE BEAT FREQUENCY OSCILLATOR ... ..	38
6. PRACTICAL RECEIVERS—Receiver Alignment—Coil Data ...	40
7. POWER SUPPLIES ... ..	57
8. AERIALS FOR COMMUNICATIONS ... ..	67
APPENDIX ... ..	71

## CHAPTER I

### GENERAL CONSIDERATIONS

The Communications Receiver has, by reason of the many commercial types now advertised, become a familiar feature to most readers of amateur and professional radio literature, but the high price of such a receiver makes it, for most amateurs and short-wave listeners, quite out of reach. As the name implies, the communications type of receiver is primarily designed to provide the listening side of a complete radio station, especially in the amateur station, so that the set has controls intended to work in conjunction with a transmitter, but in the main such a receiver is a highly efficient instrument of great use and value to any experimenter working on the higher frequency bands.

The ordinary "all wave" receiver is not ideal for short-wave work, and, of course, is almost useless for the frequencies above approximately 20 mcs.—that is for wavelengths below about 15 metres, for although a V.H.F. converter can be fitted to such a set, the results will never be so satisfactory as those obtained with a receiver specially designed for such work. In some cases a communications receiver does not work at frequencies above 30 mcs., but in this case a converter preceding the set will give excellent results, since the main receiver is capable of working with so much greater efficiency.

The main outline of a communications receiver will contain features such as the following: An input circuit providing for both dipole and single wire aerial feeds into a pre-selector stage, giving R.F. amplification and thus extra selectivity, with a high image ratio. The frequency-changer following such a stage may consist of a single valve in the usual way, or may have a mixer valve fed with local oscillations from a separate oscillator. The use of a separate oscillator allows the injection of local oscillations to be adjusted to the optimum, whilst the overall gain of such a frequency converter can be greater than that obtained from a triode hexode, a triode pentode or a pentagrid.

The I.F. amplifier following the frequency converter is often the real heart of the communications receiver. Whereas the ordinary broadcast receiver has a single I.F. stage, the I.F. amplifier in the communications receiver generally consists of at least two stages, and in commercial models a series of pass-bands is provided so that the overall selectivity of the set is readily changed to suit the signal or conditions—for example, to receive a broadcast or programme signal the pass-band of the receiver will be broadened in order that the sound quality shall not suffer, but for reception of signals in the amateur bands, where the highest selectivity is required, and where some degree of tone value may be sacrificed, the pass-band is then reduced to give a very narrow degree of selectivity.

In the best I.F. amplifiers is incorporated a "crystal gate." A quartz crystal, similar to those used to stabilise crystal oscillators, except that it is cut to resonate at the intermediate frequency, is used as a tuned circuit



with a very high efficiency or Q, giving a very narrow pass-band, so that in cases where stations on adjacent frequencies are suffering mutual interference which cannot be prevented even with the I.F. at its most selective setting, switching in this "crystal gate" will generally allow the required station to be tuned free of interference, so great is the extra selectivity obtained.

In the I.F. amplifier, in many cases, are incorporated "S" or "R" meters, analogous to the Magic Eye used as a tuning indicator in broadcast receivers from one point of view for, like the Magic Eye, the "S" meter gives an indication of field strength. The meter in general use is a moving coil current measuring instrument, calibrated in decibels or "S" points and connected either in series with the high tension supply to a number of R.F. or I.F. amplifying stages with A.V.C. control, or in a bridge-network between anode and screens of R.F. and I.F. amplifying stages. Reports of station quality and reception strength are made by the R.S.T. code, where the symbols R1 to R5, are used to give indications of readability, the symbols S1 to S9 are used to give indications of signal strength and the symbols T1 to T9 are used to give indications of the purity of the tone. These symbols are used more especially in C.W.—i.e., in telegraphy—work, and in telephony have been replaced to some extent by the QSA and the QRK codes. The symbols QSA1 to QSA5 indicate degrees of signal strength whilst the symbols QRK1 to QRK5 indicate degrees of readability. Probably the symbols S1 to S9 are the most used, however, for reporting signal strength, and it is this series of "S" points which appears on the dial of the "S" meter.

Whilst the majority of "S" meters have the points separated by a 6 decibel reading, there appears to be no real standardisation of the S9 reading—an S9 indication being given in some cases by a 50 microvolt signal at the receiver's input sockets and in other cases by a 100 microvolt input, but even so differing conditions and even differing frequency bands will render the calibration untrue. It would appear to the author that rather too much reliance is placed on the "S" meter by many amateurs, but in a later chapter certain suggestions are made for the more valuable use of the instrument.

The detector in the communications receiver may be considered as being part of a group of stages rather than as a single valve, for associated with the detecting or demodulating diode circuit are the Beat Frequency Oscillator and the Noise Limiter. Both are necessary if the receiver is to fulfil all the usual functions.

The B.F.O. is a small self-contained stage built round a triode, in the majority of cases, and is simply an oscillating circuit working on a frequency close to the I.F. of the receiver. It is used for C.W. reception, although in certain specialised tests or adjustments it may be used when telephony is being received.

The B.F.O. is necessary to allow plain C.W. reception on a superhet. The aerial is receiving an unmodulated train of waves, and thus while the characters of the code will be passed through the frequency converter and the I.F. stages of the receiver in the usual manner, the demodulator will have no audio signals to pass on to the output stage, so that at best there will be merely a succession of clicks in the headphones or loudspeaker,

whilst a weak C.W. station will give no audible results at all. The effect may be overcome at the transmitting end by modulating the carrier-wave with tone signals; but the same result may be obtained at the receiver with much less trouble.

By switching in the B.F.O., working at, say, 1,000 cycles away from the intermediate frequency, unmodulated signals arriving as I.F. dots and dashes at the demodulator will be heterodyned by the oscillations generated by the B.F.O. and, moreover, the heterodyne will be audible since it is a 1,000 cycles note. Thus, the B.F.O. and I.F. stages, working in conjunction into the demodulating stage, give audio signals on C.W. with the added advantage that the tone or note may be adjusted to suit the ear simply by tuning the B.F.O. and thus varying the heterodyne frequency. The tuning control may be pre-set or may be brought out to a panel control, whilst a switch controls the B.F.O. as a unit. The oscillations from the B.F.O. are fed directly to the demodulator through a very small capacitance.

The detector or demodulator is most usually the conventional diode or double diode, with full A.V.C. arrangements, although other circuits are sometimes used, especially in amateur-built apparatus. The Infinite Impedance Detector, using a triode with cathode follower connections, is very useful as a detector, but with this or any other special circuits, separate stages are then necessary to give A.V.C. voltages, whilst it is possible for such high efficiency in the last I.F. tuned circuit to be obtained that the chances of feedback and instability are increased.

The Noise Limiter, like the B.F.O., is a self-contained unit, and may be switched in or out of circuit as required. Several circuits are available, the most common being a double diode biased in such a manner that audio is passed without interference. Sudden peaks of noise, however, rising above audio level, are clipped to the level set by the biasing, and in the case of ignition and similar noises it is found that clipping the noise to the level of the audio signal in the headphones or loudspeaker enables the signal to be copied without trouble.

The audio amplifying stage or stages of the receiver may be made to provide facilities for the type of work it is desired to carry out. In the first place, both headphone and loudspeaker output sockets should be provided, so that the demodulator should be followed by a triode to feed the headphones and also the power output stage for the loudspeaker. Again, some amateur operators are interested in recording their contacts so that a cutting head stage may be incorporated in the receiver, with its associated balancing networks, and then a microphone pre-amplifier is, in some cases, also enclosed in the receiver cabinet with further provision for record playback. These refinements are not usually required, however.

The outline of the communications receiver, therefore, may be shown in block diagram as in Fig. 1, where the various stages are well marked. It is now necessary to review some special points in greater detail.

In the first place, the construction of a communications receiver must be most carefully carried out, not only from the electrical but also from the mechanical viewpoint, for complete rigidity and stability are necessary. Again, the multiplicity of R.F. and I.F. stages necessitates very complete shielding to prevent feedback, and with this end in view it is usual to run

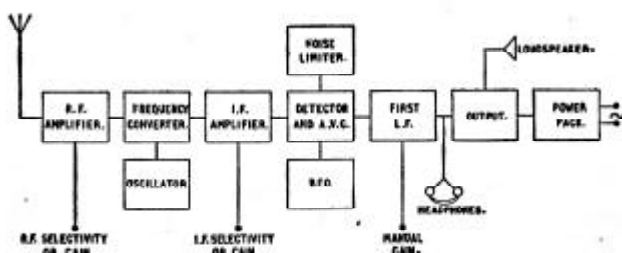

FIG. 1. The Communications Receiver in Block Diagram.

the H.T. line at a lower potential than in a broadcast receiver. A 250-volt line is all that is required, so that a 250-0-250 volt H.T. secondary transformer may be used in the power pack.

Since frequency drift in the receiver would result in the misalignment of the R.F. and oscillator tuning, the power pack is often kept separate from the receiver and given a chassis and screening cover of its own, and to avoid enlarging the receiver cabinet it is also wise to house the loudspeaker separately. It is possible to incorporate temperature compensating condensers in the oscillator circuit, and to run the oscillator from a supply line which is held at constant potential by a regulator, but these precautions need not be taken unless a high degree of accuracy is required.

In a home-constructed receiver probably the most difficult part of the design and construction is that connected with the tuning arrangements. Tracking between the R.F. and oscillator tuning obviously must be excellent, yet at the same time as great a coverage as possible is necessary and tuning must not be cramped. It therefore becomes difficult to use commercially-made coils since these are chiefly designed to work in conjunction with a 500 mmfd. tuning condenser, whereas a 50 mmfd. to a 150 mmfd. capacitance is a more suitable maximum capacity. By using home-made coils a smaller tuning condenser can be built into the receiver, but in this case the ganging of the coils for correct tracking must be performed experimentally to obtain good reception over the bands. One method of overcoming the difficulty is to use separate tuning condensers for R.F. and oscillator circuits, but again this is suitable only on the highest frequency bands, and sacrifice of single-knob tuning control (apart from a handspreading device) is a sacrifice of both convenience and simplicity.

There is also the choice between band-switching and coil-changing to be considered. Where a small receiver is desirable a set of plug-in coils assists considerably in reducing chassis size, whilst at the same time a complicated switching system and shielding arrangement is obviated, but for a comprehensive circuit band-switching is preferable. All these problems, however, are finally dealt with in a later chapter.

It has already been said that the I.F. amplifier is the heart of the receiver, and the choice of intermediate frequency also requires some thought. Image

rejection is the real point at issue, and a note upon images may be helpful at this point.

An image is caused by lack of selectivity in the first tuned circuits of a receiver, and thus image reception becomes more and more in evidence as the signal frequency rises. Consider a converter or mixer stage working into an I.F. amplifier where the I.F. is 450 kcs. If a signal to be received has a frequency of 1 mc., the oscillator, working as is usual on the high side of the signal, will feed into the mixer a 1.45 mcs. signal, so that the final result will be the 450 kcs. heterodyne.

At the same time, however, a signal from a station on 1.9 mcs. will also beat with the oscillator on 1.45 mcs. to produce a signal at the I.F. of 450 kcs.; or, from a second point of view, the original station at 1 mc. will be heard first, when the oscillator is working on 1.45 mcs. and, secondly, when the oscillator is tuned to 0.550 mcs. or 550 kcs.

The possibility exists, therefore, with any superhet, of tuning in each receivable station at two points on the dial.

At the frequency of the station given as an example, 1 mc., the reception of an image is virtually impossible, however, for the selectivity of even a single tuned circuit is sufficient to prevent a 1 mc. station from feeding through to the mixer when the first tuned circuit is set at 100 kcs. as it will be when the oscillator is working at 550 kcs., but the percentage difference reduces rapidly as station frequency rises. For example, maintaining the I.F. at 450 kcs., a station on 10 mcs. will give an image when the first tuned circuit is set at 9.1 mcs., the oscillator then being set at 9.55 mcs., and whilst admittedly the tuned circuit which would pass a 10 mcs. signal when the circuit itself was set at 9.1 mcs. would be rather poor, the effect becomes possible, and then pronounced before the 10-metre amateur band on 30 mcs. is reached. Here the image reception of a 30 mcs. signal can take place when the first tuned circuit is set at 29.1 mcs., and there will be sufficient transference in this case to give a strong image. (These figures are given assuming that the oscillator is still working at a higher frequency than the first R.F. or signal frequency. Often, however, the oscillator works at a lower frequency for reception of 10-metre signals—this consideration does not, of course, affect image reception, which is still possible.)

An obvious solution to this trouble with image reception is to increase the I.F. of the receiver. I.F. transformers working on a frequency of 1.6 mcs. are obtainable, and will help considerably in reducing image reception, whilst for a superhet to be used exclusively on the higher frequencies or the very high frequencies, an I.F. of 5, 10 or even 15 mcs. is quite common. Increasing the I.F., however, is only possible by sacrificing the coverage of the receiver, for if signals in the medium-wave broadcast band are also to be received, say, on 750 kcs., the I.F. cannot, for obvious reasons, be much greater than the usual 450 kcs. or so.

A second solution to the problem of image reception is to use an I.F. of 450 kcs. or a similar frequency and to improve the selectivity of the "front end" of the receiver as far as possible. This is the purpose of the R.F. amplifying stage, which improves selectivity as well as sensitivity, and a regenerative R.F. stage gives even greater image rejection. For the V.H.F.'s. the most convenient method of reception is to use a converter

feeding into the main receiver, when the 5-metre band and signals at even higher frequencies can be received.

By the use of a converter the superhet is changed to double I.F. working, for the converter's oscillator works at a frequency separated from the signal by 5 or 10 mcs. A tuned transformer connects the converter to the receiver's input terminals, the receiver also being tuned to 5 or 10 mcs., which thus becomes the first I.F. The frequency converter in the main receiver then further converts this first I.F. to the receiver I.F. of 450 kcs. or so, which becomes the second I.F.

With the choice of the intermediate frequency settled, the controls of the I.F. amplifier may be considered. To obtain variable selectivity, two methods at least are available, one being the use of variable selectivity transformers and the other to make one stage of the I.F. amplifier regenerative, the selectivity varying with the degree of regeneration allowed. Since regeneration may be controlled by simple means—a variable resistance in the cathode circuit of the valve involved, for example—selectivity control is readily available without the expense of special transformers. The crystal gate, with its particular circuit and requirements, is dealt with in Chapter 4.

When the I.F. amplifier feeds into a conventional diode detector and A.V.C. stage, it is generally found that one or two disadvantages are attendant on the circuit. The B.F.O., for example, cannot be used when the A.V.C. line is operating, for the local oscillator then feeds into the A.V.C. circuit and thus affects the biasing of the A.V.C. controlled stages. At the same time, the "S" meter is generally switched out of circuit when the A.V.C. line is switched out of action. These effects can be remedied if a rather more elaborate detector and A.V.C. circuit is arranged. For example, by using one side of a double triode as a detector of the Infinite Impedance type, taking due precautions over the I.F. feed if necessary, the other side of the double triode may be used with great success as the B.F.O. and, at the same time, the B.F.O.-Detector coupling problem is solved, for with both valves in the same envelope the coupling is provided within the valve. Also, it is then possible to tap the A.V.C. rectifier into the I.F. amplifier ahead of the detector, with the result that the B.F.O. may be used with the A.V.C. either off or on, just as is required. Again, the "S" meter may be connected, not to the I.F. or R.F. stages of the set, but to a valve controlled by the A.V.C. line and set apart for meter operation, this valve being connected to the A.V.C. line whether it is switched in to control the receiver or not, the "S" meter then giving its indications at all times. This meter-controlling valve may be combined with the A.V.C. rectifier in the form of a double diode triode or a double diode pentode, thus making the circuit less extensive than might at first appear.

It will be seen, then, that the communications receiver may take many forms, and the circuit details and the more important of these features will be further examined in the following pages. One particular function of the receiver must first be noted, however, together with the special arrangements and circuits used—the use of the receiver with the amateur transmitter.

## CHAPTER 2

### THE RECEIVER AND THE TRANSMITTER

Where the communications receiver is used alone, the "Standby" switch is probably never touched, but to the transmitting amateur it is possibly one of the most-used controls. The Standby switch cuts the H.T. supply from either the whole or the R.F.-I.F. portions of the receiver, whilst leaving the valve-heaters on so that the set is ready to commence work again as soon as the switch is thrown. It is obvious that the transmitter and receiver cannot work in the same band together unless several precautions are taken, and, so far as 'phone operation is concerned, the chief precaution is to open the Standby switch as soon as the replying station has finished a call. The transmitter's Standby switch is then closed, so that at no time does the set receive a signal from the transmitter of its own station.

Even so, the input circuit of the receiver is still open to receive applied power from the transmitter, and in a high power system, with receiver and transmitter tuned to the same or adjacent frequencies, it is still quite possible for a high current to flow in the input or first tuned receiver circuit, a current sufficiently high to cause damage.

Where the receiver is connected to the same aerial as the transmitter, it will obviously be necessary to arrange for the aerial to be switched from the receiver to the transmitter when a transmission is to take place, and if, as is usual, relay switching is used for this purpose, it is a simple matter to arrange a further relay contact to short out or ground the receiver's input sockets. When a separate aerial is used for the receiver, however, so that no aerial-switching is necessary, the receiver's input sockets should still be earthed or short-circuited, and in some stations an adaption of the "press-to-talk" method of switching is used, a press-button on or beside the microphone operating relays which, when the button is depressed and held down throughout the conversation or call, switch off the receiver, render its input circuit inoperative and then apply power to the transmitter's anodes for the transmission.

It is advised, however, that the same aerial be used for both transmission and reception, especially when a beam or directed aerial is in use, for it is useless to make an effort to direct transmitted power over a considerable distance if the receiver is not equally well served. The aerial switching relays can then perform all the necessary operations by a simple extension of the Standby switch, so far as the receiver H.T. line is concerned, with a contact reserved for the receiver's input circuit, and the relays should be so arranged that switching on the transmitter automatically protects the receiver.

An exception to the use of one aerial for both transmitter and receiver must be made, of course, in Duplex working where two stations, generally local, have transmitter and receiver working together, the call being more in the nature of a telephone conversation, since both operators are able to work at the same time, giving question and answer without interruption. In this type of work it is generally arranged that one transmitter shall be separated in frequency from the other by practically the width of the 'phone band, so that in each location the receiver is tuned to a frequency widely different from that of the transmitter. Then the receiving and transmitting

aerials should be as well separated as possible, and, since the distance covered is usually not great, the transmitter input power is reduced as far as possible.

Again, a special arrangement is required for break-in working. Break-in working will probably become even more popular now that the British amateur is required to work C.W. for the first year of his licence, and has much to recommend its adoption. By working with break-in, C.W. operation gains character much as personality is given to a contact on 'phone by Duplex working, for one station can break in on the signals from its contacting station, question and answer can be passed back and forth, repeats of uncopied or bad characters can be requested at the moment of occurrence and, perhaps more important still, each station has a check at all times of QRM or interference on his own frequency, since even if the stations are working at different frequencies such information can be passed from one station to the other without delay.

The requirements of break-in C.W. operation are that the receiver is controlled by the transmitter at each depression of the key. Whilst the key at the transmitter is down, forming a dot or dash, the receiver at that station must be dead, but immediately the key is up, even between characters, the receiver must be in operation. This means that the second transmitter may interrupt the first by merely holding down his own key, since then he will be heard as a note or tone in the receiver at the first transmitter with every break in the transmission at that station, which then ceases to send, or sends a code group to signify readiness to receive. Separate aerials are usually used for transmission and reception.

At each station, therefore, the key controls a relay circuit, the actual circuits being arranged to the favourite scheme of the operator but capable of keying the transmitter, earthing one aerial and controlling the receiver. The relays, moreover, must be quick and quiet in operation.

At the same time, however, a monitor is required in order that the operator may check his own keying in his headphones, and the receiver at his station may be left sufficiently operative to give him the sound of his own transmitted signal. Probably the simplest method of achieving this result is to switch in extra biasing into the R.F. stage of the receiver which, although its input circuit is shorted and there is no aerial connected to it, will still be able to receive signals from the transmitter at its own station. The biasing switched in to the receiver's first stage should have a manual control, so that the operator can set the volume of his own signal in balance with that of the contacting station.

The use of a high biasing potential on the R.F. and sometimes also on the I.F. stages of the receiver is not confined to break-in C.W. operation, for it can be used also on straight C.W. or telephony transmission to enable the receiver to act as the station monitor or as the method of rendering the receiver inoperative. The Standby switch, for example, instead of breaking the main H.T. line to the receiver, may connect the A.V.C. line from the R.F. and I.F. stages to -30 or -40 volts of bias, obtained from batteries or from a small biasing unit in the power pack.

Some methods of aerial-switching and transmitter-receiver control can now be considered in greater detail.

### Aerial-Switching

The control switch which transfers the aerial feeders from the receiver to the transmitter and vice versa may be manual or relay-operated, and when other circuits are to be closed at the same time relay operation is advisable. One control button or switch can then control several relays, for in a high power system the aerial feeders should have their own separate relay and contacts mounted out of harm's way. Specially designed aerial relays are obtainable commercially.

One ingenious method of aerial-switching should be noted, however, which calls for transference of feeders from one set of connections to another. Its use is really confined to the higher frequency systems, where a quarter-wavelength feeder is of convenient size. Reference to the *Bernards' Aerial Handbook* will show that a quarter-wave line or two-wire feeder has a low impedance at one end of the line, with a high impedance at the other. Such a line can therefore be switched into the main aerial feeder in a manner that presents a practical short-circuit to the receiver, and devices based on this principle were widely used in certain radar gear. It is also possible to use gas-filled tubes—neon or argon tubes or gas triodes—as the shorting bar across an aerial-matching stub when the transmitter is coupled to the aerial through such a device. The gas-filled tube will glow when the transmitter is switched on, thus shorting the stub and matching in the transmission line to the aerial, but when the transmitter is switched off the tube is extinguished, the short-circuit becomes a high impedance and a further quarter-wave line from the ends of the matching stub to the receiver will then transfer aerial power to the receiver's input circuit. These systems, however, are unconventional, and manual or relay aerial-switching is far more common.

The transmitter is coupled to the aerial via an aerial tuning unit, and the switching may or may not include this unit. The feeders may be switched from the aerial tuning unit to the receiver, a separate aerial tuning unit may be used at the receiver or the aerial tuning unit may be connected to the feeders permanently and the unit itself switched from transmitter to receiver. The system to be used depends on the requirements of the gear in relation to the aerial, but the simplest method is to employ a switch which changes the feeders from the transmitter's aerial tuner straight to the receiver, as shown in Fig. 2.

If matching between the feeders and the receiver's input circuit is required, it can be obtained by using a unit as shown in Fig. 3. The final adjustment of such a unit must be made experimentally to suit the receiver, the chief point being that the lines from unit to receiver must always be tapped to the main coil in balance—that is, the two taps must always be an equal number of turns on either side of the centre of the main coil.

#### Components List for the Receiver Aerial-Matching Unit, Fig. 3.

- |     |   |
|-----|---|
| C1, | 100 mmfd. variable. Raymart VC100X.   |
| L1, | 12 turns 18 S.W.G. spaced on 1½" diam. former, winding gapped at centre for L2. |
| L2, | 3 turns 18 S.W.G. between halves of L1.   |
- Small chassis and tuning knob. Clips.  
(To cover 14 mc. band.)

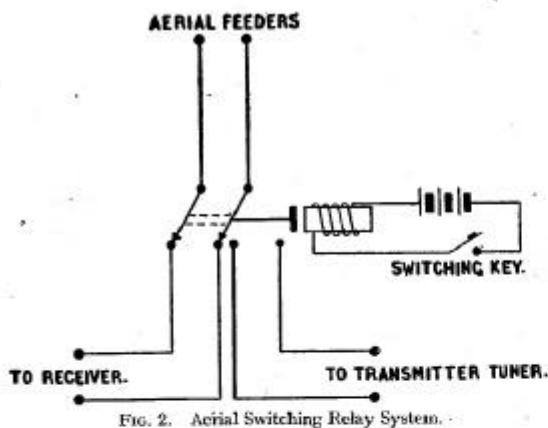

When the switching is performed by a relay, other relays controlled by the same switch or press-button being used for switching on the transmitter power, shorting the receiver input, etc., some consideration must be given to the consumption of the relay coils and the source of activating power. One commercial aerial relay (made by Londex, Ltd., who can offer various makes and types of relays) requires 3 v.a. for the coil. Different makes of relay, however, will have widely varying demands on the energising source, so that where several relays are to work as a team they must be chosen

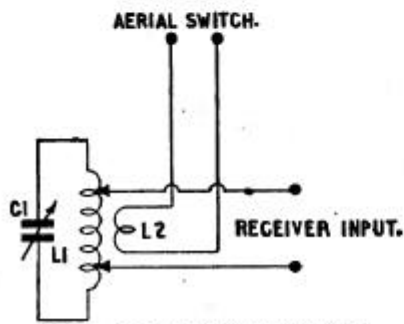

to have similar coil ratings. Low resistance relays may be driven from a six or twelve volt accumulator battery, the coils being connected in series or parallel to give a suitable total resistance, but the battery may be replaced by a simple power pack giving, say, 100 volts D.C. if high resistance/low current coil relays are used. In either case the relays should be D.C. operated to give positive action without any chance of chattering of the contacts which might occur with A.C. energisation. A.C. relays are, of course, obtainable, but the D.C. type are to be preferred.

It is by no means beyond the limits of the home workshop to adapt old relays to new uses, the best source of old relays being a car-breaker's yard, which should always be able to supply old car cut-outs.

The complete system for C.W. break-in operation shown in Fig. 4 shows how a single D.P.D.T. relay can be used for simultaneous operation of both transmitter and receiver, and will serve as an example from which other systems may be derived. Naturally there is no aerial-switching from one piece of gear to the other in this system for, as in Duplex 'phone, a separate receiving aerial is used. This aerial must be earthed, however, along with the aerial input socket on the receiver, whilst at the same time a high bias is applied to the first R.F. stage of the receiver, the bias being controlled by a potentiometer in order that the transmitter at the receiver's station can still be heard. Note that the relay contacts should be so adjusted that the receiver is off, with its aerial earthed, a fraction of a second before the transmitter is keyed, and that the transmitter is switched off just before the receiver comes back into operation.

It will be seen that the key is in the relay coil circuit, so that a high resistance relay will give a low keying current with less sparking at the key contacts, but a key filter is shown in circuit. The relay contacts which "key" the transmitter should be connected in circuit at a suitable point to give good working, in the negative supply lead to the crystal oscillator, for example.

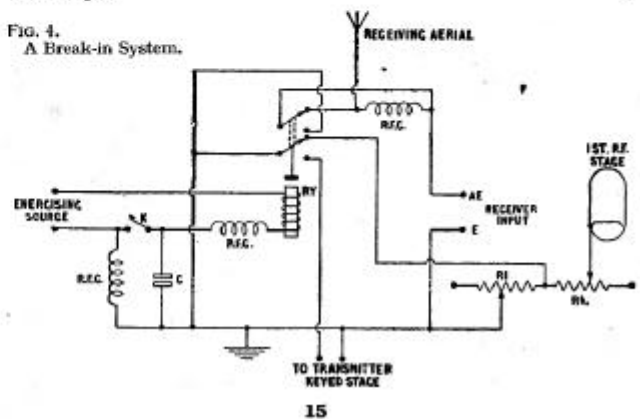



Components List for Relay System, Fig. 4.

K,	Key.
R.F.C.,	R.F. Chokes, as Eddystone, 1022.
C,	0.01 mfd. 500 v.w. Non-inductive.
R1,	0.5 megohm. Volume control.
Rr,	Receiver's volume control.
Ry,	D.P.D.T. relay.

The new volume control, operative only on the transmitter at the receiving end, may be mounted externally to the receiver. This break-in system will work when the two stations in contact are on different or the same frequencies.

The provision of a high bias line in the receiver, to which is connected the Standby switch, is a matter of receiver design and thus appears in more detail in later pages.

CHAPTER 3

PRACTICAL RECEIVING CIRCUITS

It is the purpose of this chapter to show some of the stages and circuits used in a communications receiver, not only that their method of working might be better understood but that the amateur with a small receiver may be able to incorporate one or more of these stages, thus improving his gear with the minimum of trouble and expense. An R.F. amplifying stage might be inserted between aerial and receiver, for example, thus acting as a pre-selector with individual tuning, or a stage in the I.F. amplifier might be made regenerative to give a degree of I.F. selectivity control and extra gain.

The R.F. Stage

The R.F. stage of a communications receiver is required to carry out a number of tasks. It is required to amplify the signal at its original frequency, to tune as sharply as possible in order that image rejection shall be high and the selectivity of the receiver as a whole shall be enhanced, it contains, as a stage, the first gain control of the receiver and it must work at all the frequencies for which the receiver is intended.

The amplification obtained from an R.F. stage varies with frequency, the gain falling as the frequency rises, and at very high frequencies not only does the efficiency of the first tuned circuit fall, but the loading presented to this circuit by the valve increases rapidly. The valve to be used in the R.F. stage must therefore be chosen to suit one particular set of requirements—Acorns, however, in their pentode ranges, give probably the best all-round results, but it should be remembered that at least three characteristics are under comparison when an R.F. valve is to be chosen. These three characteristics are the Signal-to-Noise ratio, Selectivity and Gain.

The valve types which might be used in an R.F. stage can be classed very broadly as R.F. Pentodes, Television Pentodes and Acorn Pentodes. Where selectivity is not so important, the Television Pentodes give high gain with

quiet working, but where selectivity is the first requirement an Acorn should be used. The selectivity of a Television Pentode stage can be improved by making the stage regenerative, however, the regeneration being controlled by the usual manual gain control in the valve cathode circuit.

In Fig. 5 is shown a regenerative R.F. stage. Feedback between the two tuned circuits provides the regeneration coupling, and the two circuits should be screened from each other in order that feedback shall remain under control. The pre-selector is not used under conditions of actual oscillation, of course, but the cathode control is advanced towards the oscillating point for greater gain and selectivity, whilst an initial control over the feedback is exercised through the anode tap on to the anode coil.

The pre-selector shown in Fig. 5 is more suitable for use with an existing receiver than for incorporation in a communications circuit, however, if for no other reason than that an untuned anode stage is preferable to enable the R.F.-Mixer stage coupling to be arranged easily, but a simple R.F. stage such as is shown in Fig. 6 can still be made regenerative by arranging the wiring in such a manner that a small degree of feedback from anode to grid circuits is obtained. Such wiring arrangements must be made experimentally in order that the correct feedback is applied, and the notes on the regenerative I.F. stage may prove helpful in this respect.

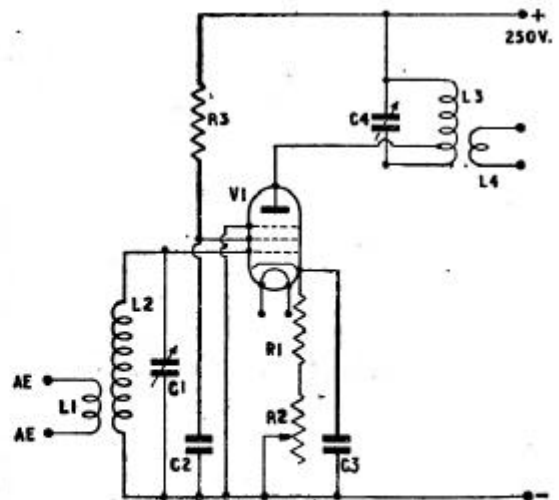

FIG. 5. A Regenerative R.F. Stage

**Components List for the Regenerative Pre-Selector, Fig. 5.**

- C1, C4, 40 mmfd. tuners, ganged. Raymart VC40X.  
 C2, C3, 0.01 mfd. 350 v.w. Non-inductive.  
 R1, 150 ohms,  $\frac{1}{2}$  watt.  
 R2, 5,000 ohms, variable.  
 R3, (For 4 volt operation) 33,000 ohms, 1 watt.  
 R3, (For 6 volt operation) 62,000 ohms, 1 watt.  
 V1, SP41 for 4 volt operation.  
 1852 for 6 volt operation.

- 1 International or Mazda octal chassis mounting valveholder.  
 Small chassis, with valve and coil shields.  
 2 coil-holders, Eddystone 964.  
 Coupler for C1, C5, Eddystone 529.  
 Slow-motion drive.  
 Knob for R2.

**NOTE.**—To obtain bandsread tuning, use in place of C1 and also in place of C4 a 3-30 mmfd. trimmer, adjusted for bandsset, and tune with 15 mmfd. tuners, Raymart VC15X, ganged.

**Coils, for amateur band coverage.**

- L1. 3.5 mcs. 10 turns 22 S.W.G. enam. close-wound below L2.  
 7 " 5 " " " " " " " " "  
 14 " 3 " " " " " " " " "  
 28 " 2 " " " " " " " " "  
 L2. 3.5 mcs. 55 turns 22 S.W.G. enam. wound to length of  $1\frac{1}{2}$ ".  
 7 " 24 " 20 " " " " " " "  
 14 " 12 " " " " " " " " "  
 28 " 5 " 18 " " " " " " "  
 L3, L4, as L1, L2. Tap L3, as testing points for further trials, at 8 turns up for 3.5 mcs., 6 turns up for 7 mcs., 3 turns up for 14 mcs., and  $1\frac{1}{2}$  turns up for 28 mcs.

All coils on  $1\frac{1}{2}$ " diameter forms, as Eddystone 537.

**Components List for R.F. Stage, Fig. 6.**

- C1, 40 mmfd. Bandsset. Raymart VC40X.  
 C2, 15 mmfd. Bandsread. Raymart VC15X.  
 C3, C4, C5, 0.01 mfd. 350 v.w. Non-inductive.  
 R1, (For 4 volt operation) 33,000 ohms, 1 watt.  
 R1, (For 6 volt operation) 62,000 ohms, 1 watt.  
 R2, 150 ohms,  $\frac{1}{2}$  watt.  
 R3, 5,000 ohms variable.  
 V1, SP41 for 4 volt operation.  
 1852 for 6 volt operation.  
 1 Mazda or International octal chassis mounting valveholder.  
 L1, L2, Aerial input and first tuning coils. As coils for Fig. 5 or as coils already fitted to receiver. C1, C2, may also be substituted by condenser gang in receiver.  
 L3, primary of R.F. transformer, coupling into second stage or mixer.

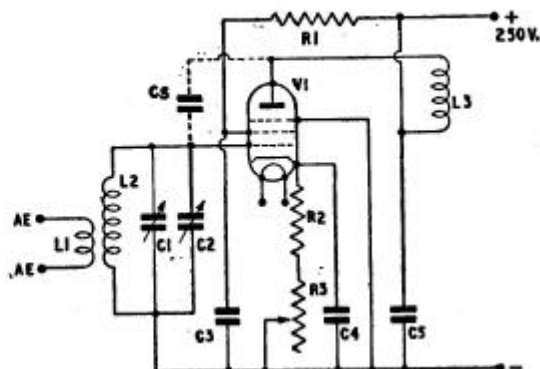

FIG. 6. An R.F. Stage.

Obtain regeneration by small stray capacity, CS, shown dotted in Fig. 6, or by running leads to C1, C2, near to tuned circuit leads of following stage, thus obtaining a small feedback in correct phase.

**The Frequency Converter**

If the receiver is to be kept small and inexpensive, it may be permissible to dispense with the R.F. stage and to feed directly into the frequency converter stage, provided that some method is used to improve the image rejection of the input stage. Here again, however, the frequency converter, or mixer, can be made regenerative by the use of a conventional grid-anode coupled coil system, and the amateur requiring a small receiver with good selectivity would do well to test such a mixer against a straightforward circuit. The regeneration control is a variable resistance across the anode coil and is used, naturally, so that at no time does the mixer actually oscillate. It is difficult to avoid a slight de-tuning effect on the first tuned circuit as the regeneration control is used, but the advantages consequent on the circuit outweigh the slight disadvantages.

Moreover, in a receiver sufficiently simple to use no R.F. stage, the oscillator and input tuning may quite satisfactorily be separately controlled, with tracking maintained not by trimming and padding methods but through the tuning, tracking thus being under control at all times. In such a receiver a slight tuning shift in the input tuned circuit will be of no consequence, and a regenerative mixer, using a triode-heptode, is shown in Fig. 7. A pentagrid converter may be used in the same manner, although when using a valve of this type it is advisable to inject the local frequency from a second oscillator, whose circuit may be the conventional triode oscillator, this type of frequency converter proving more satisfactory on the high frequencies.

**Components List for the Regenerative Frequency Converter Stage, Fig. 7.**

- C1, C4, 60 mmfd. tuners. Raymart VC60X.  
 C2, C3, C5, 0.01 mfd. 350 v.v. Non-inductive.  
 C6, 8 mfd. 350 v.w. Electrolytic.  
 C7, 0.1 mfd. 350 v.v. Non-inductive.  
 C8, 0.0001 mfd. Mica.  
 R1, 10,000 ohms, variable.  
 R2, 220 ohms,  $\frac{1}{2}$  watt.  
 R3, 47,000 ohms,  $\frac{1}{2}$  watt.  
 R4, 15,000 ohms, 1 watt.  
 R.F.C., R.F. Choke, Eddystone 1010 or similar.  
 V1, ACTH1 for 4 volt operation.  
 6K8 for 6 volt operation.
- 1 Mazda or International octal chassis mounting valveholder.  
 Slow-motion drive for C4.  
 Knobs for C1, R1.

**Coils, for amateur band coverage.**

L1.	3.5 mcs.	10 turns 22 S.W.C. enam.	close-wound, above L3.
L2.	" "	12 " " "	" " below L3.
L3.	" "	45 " " "	" " $1\frac{1}{2}$ " long.
L4.	" "	40 " " "	" " "
L5.	" "	15 " " "	close-wound, below L4.
L1.	7 mcs.	6 turns 22 S.W.G. enam.	close-wound, above L3.
L2.	" "	8 " " "	" " below L3.
L3.	" "	22 " 18 " "	" " $1\frac{1}{2}$ " long.
L4.	" "	17 " " "	" " "
L5.	" "	8 " 22 " "	close-wound, below L4.
L1.	14 mcs.	5 turns 22 S.W.C. enam.	close-wound, above L3.
L2.	" "	6 " " "	" " below L3.
L3.	" "	10 " 18 " "	" " 1" long.
L4.	" "	8.5 " " "	" " "
L5.	" "	5 " 22 " "	close-wound, below L4.
L1.	28 mcs.	4 turns 22 S.W.C. enam.	close-wound, above L3.
L2.	" "	2 " " "	" " below L3.
L3.	" "	4 " 18 " "	" " 1" long.
L4.	" "	3.5 " " "	" " "
L5.	" "	2.5 " 22 " "	close-wound, below L4.

All coil sets wound on  $1\frac{1}{2}$ " forms, as Eddystone 537. Separation between coils approx.  $\frac{1}{4}$ " (between L1, L2, L3 on one form, and between L4, L5 on second form).

**The I.F. Amplifier**

When an intermediate frequency of approximately 450 kcs. is chosen, two I.F. stages will give as much gain as can be handled and, providing that iron-cored I.F. transformers are used, selectivity will be good and image rejection at a high ratio until the 14 mcs. band is reached. An R.F. amplifying stage between the converter and the aerial will, however, keep the

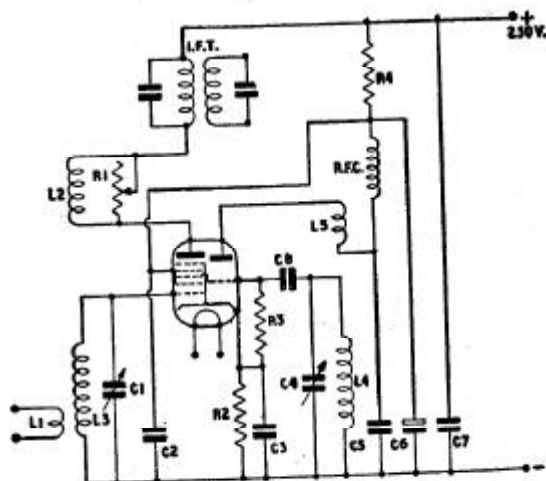

FIG. 7. A Regenerative Frequency Converter

image rejection satisfactory up to about 20 mcs., whilst on the 28-30 mcs. amateur band reliance must be placed on the extra rejection obtained by regeneration in the R.F. stage.

Variable selectivity in the I.F. amplifier is achieved, as has already been seen, either by the use of special I.F. transformers with variable couplings between their primaries and secondaries, such couplings being controlled either mechanically or electrically, or by making the I.F. stage regenerative, the regeneration control being once again in the valve's cathode lead.

Since variable- $\mu$  valves are almost always used for I.F. stages, in order that they may be effectively controlled from the A.V.C. line, this type of regeneration control gives very good results, although it must be realised that the percentage of regeneration over the stage varies with the signal being received, so that selectivity is rather less on a strong signal than on a weak one.

Only one stage of the I.F. amplifier is given variable selectivity by regeneration, the first stage, that following the frequency converter, usually being the controlled stage.

It is, perhaps, simpler to introduce regeneration into an I.F. amplifier working on 450 kcs. than into a stage with a higher intermediate frequency of, say, 1,600 kcs.—and, at the same time, maintain stability over the whole amplifier.

If a crystal circuit is to be used in the I.F. stage, several different degrees of selectivity can be obtained, but in this case it is wise to use



variable selectivity transformers rather than a regenerative I.F. amplifier. The Crystal Gate, however, is fully dealt with in Chapter 4, and the remarks concerning I.F. amplifiers at this point refer to receivers where no crystal is used.

The sharper selectivity curve of a regenerative I.F. stage has a pronounced effect on C.W. reception, when using the B.F.O. A broad I.F. curve working against the B.F.O., with the signal tuned centrally on to the I.F. curve and the B.F.O. set to give, say, a 1,000 cycles beat note, will allow the signal to be heard in a varying range of pitch, whilst an interfering signal, breaking through the first tuned circuits and producing a second signal in the I.F. amplifier a few kcs. off resonance, will produce a second beat note which may be at the same audio frequency as the desired signal. To prevent this type of interference, the I.F. curve is sharpened to give Single-Signal reception. Whilst true Single-Signal reception is really obtained by the use of a crystal gate, a very good approximation to this working condition can be achieved by introducing feedback into the I.F. stage.

The sharper curve given to the I.F. response allows the desired signal to be heard beating against the B.F.O. at only one point, so that the change of pitch with tuning is not observed. At the same time, unwanted signals which may break through the first tuned circuits will be rejected by the I.F. amplifier, and the result is that whereas, formerly, a signal could be heard on either side of zero beat, with single-signal reception the signal will be heard on only one side of the zero beat point, the response on the other side being so far down as to make the signal either very weak or inaudible.

Introducing regeneration into the I.F. amplifier is a very simple matter since once again all that is required is a small capacity between the grid and

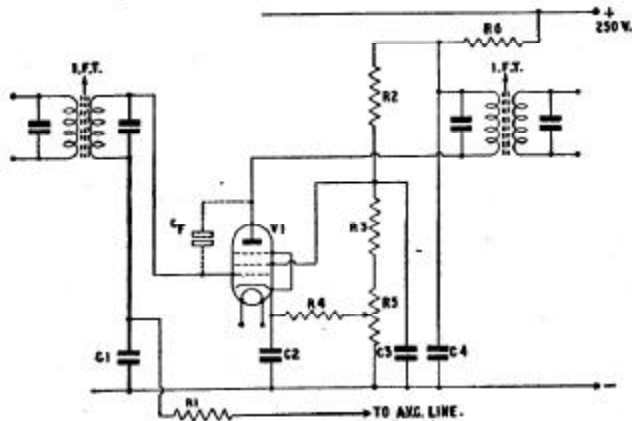

FIG. 8. A Regenerative I.F. Stage.

anode circuits. In a really stable stage a small trimmer condenser can be used, with the top or moving plate freed from the adjusting screw and bent up at a sharp angle from the bottom plate so that the final capacity of the arrangement is very small, but it is also possible to obtain the effect by running a wire from the grid circuit close to the anode circuit, clipping the wire down to size until regeneration is at the correct degree.

If a single-ended valve is used, such as an EP50, the small capacity can be arranged between the grid and anode sockets at the valveholder, but when, as is more usually the case, a top cap grid valve is used, the capacity can be arranged between the secondary of the input I.F. transformer and the primary of the output I.F. transformer.

It is wise to reduce the gain of a regenerative I.F. stage by running the valve at a higher bias. By this means, selectivity is increased and the chances of overloading the stage reduced, whilst at the same time there is greater regeneration control.

A regenerative I.F. stage is shown in Fig. 8, and it will be seen that it follows closely ordinary practice. It will be seen that the introduction of regeneration makes no difference to A.V.C. control on the stage.

*Components List for a Regenerative I.F. Stage, Fig. 8.*

- C1, 0.01 mfd. 350 v.w. Non-inductive.
- C2, C3, C4, 0.1 mfd. 350 v.w. "
- R1, 0.22 megohm,  $\frac{1}{2}$  watt, or to suit whole A.V.C. circuit.

*For 4 volt operation:—*

- R2, 10,000 ohms,  $\frac{1}{2}$  watt.
- R3, 68,000 "  $\frac{1}{2}$  "
- R4, 330 "  $\frac{1}{2}$  "
- R5, 25,000 ohms variable.
- R6, 2,200 ohms,  $\frac{1}{2}$  watt.

*For 6 volt operation:—*

- R2, 33,000 ohms,  $\frac{1}{2}$  watt.
- R3, 22,000 "  $\frac{1}{2}$  "
- R4, 330 "  $\frac{1}{2}$  "
- R5, 25,000 ohms variable.
- R6, 2,200 ohms,  $\frac{1}{2}$  watt.
- I.F.T. 1, 2, 465 kcs. Iron-cored transformers.
- V1, VP41 for 4 volt operation.  
6SK7 for 6 volt operation.

1 Mazda or International octal chassis mounting valveholder.  
The feedback capacity, CF, is not included in the parts list.

*The Detector and A.V.C.*

The diode detector or demodulator needs no explanation since it is such a widely-used circuit, but the alternative detector most suited by its characteristics for use in a communications receiver, the infinite impedance detector, is shown in Fig. 9.

The detector does not impose a load on the tuned circuit to which it is connected, so that selectivity in the final tuned circuit can be kept high, this condition depending on the fact that the load resistance of the circuit across which the audio voltages are developed is in the cathode lead, giving high negative feedback. The anode current is very low, rising with signals, so

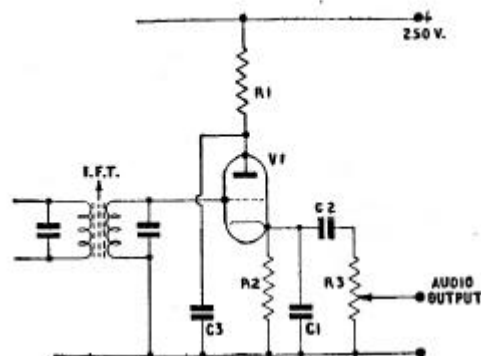

FIG. 9. The Infinite Impedance Detector.

that in no circumstances can the grid become positive with respect to the cathode, with the result that grid current cannot flow.

The high negative feedback gives excellent quality, and whilst no amplification is obtained from the valve, as is the case with other "cathode follower" circuits, this detector is well worth using when the receiver is to be used for programme work as well as for amateur contacts.

A filter network should be included in the anode supply line to prevent any chance of hum appearing in the output from the detector.

A separate valve must be used for the supply of A.V.C. voltages, but this is often an advantage in the communications receiver, for the separate A.V.C. valve can then be tapped into the I.F. amplifier at a point where the response curve is broader than the final response at the detector end. This method of A.V.C. feed is sometimes employed for one diode of a double diode, but here care must be taken when a crystal gate is introduced into the I.F. amplifier, for if one diode is tapped into circuit before the crystal and the second, employed as a detector, follows the filter, a small capacitance between the diodes of the double diode valve will be connected across the crystal gate with some slight loss in its efficiency.

An infinite impedance detector gives excellent results when following a crystal gate.

**Components List for the Infinite Impedance Detector, Fig. 9.**

- |     |  |
|-----|--|
| C1, | 0.0002 mfd. Mica.  |
| C2, | 0.1 mfd. 350 v.w. Non-inductive.   |
| C3, | 0.5 mfd. 350 v.w.  |
| R1, | 22,000 ohms, $\frac{1}{2}$ watt.   |
| R2, | 150,000 ohms, $\frac{1}{2}$ watt.  |
| R3, | 0.25 meg. Volume control.  |
| V1, | MHL4, 224 v., etc., for 4 volt operation.<br>6CS, 6J5, etc., for 6 volt operation. |

1 British 5-pin or International octal chassis mounting valveholder.

When a separate valve is used for A.V.C., it may be either a diode, limited to the one operation of supplying the control voltage to the receiver's A.V.C. line, or may be a double diode or pentode, the main section of the valve being fed from the A.V.C. voltage at all times and having the "S" meter in its anode circuit, the "S" meter thus being freed from the usual limitation of working only when the receiver has the A.V.C. switched on. If it is desired to use a diode as a simple A.V.C. supply, a purely conventional circuit is used, but when the full advantages of A.V.C. and "S" meter are to be taken, the circuit of Fig. 10 is capable of giving excellent results.

It will be seen that the anode current of the pentode section passes through the "S" meter so that a shunt resistance, R7, must be provided. Where a meter is used in this fashion it reads "backwards"—that is, for "S" zero the pointer is set to full-scale position, the reading decreasing with increasing signal strength, since increasing signal strength places a more negative bias on the grid of the meter pentode, thus causing the anode current to fall.

In commercial receivers the meter used is arranged to have the no-current, zero position at the right-hand side of the scale instead of at the conventional left-hand side, but a simple solution for the amateur constructor is to mount the instrument upside down, so that with the current switched off the pointer is at the right-hand side of the dial. With the current adjusted to give full-scale deflection, or "50" zero, the pointer will then be at the left-hand side of the scale, increasing signal strength bringing it across scale from left to right in the usual manner. This, of course, means that the instrument used for the "S" meter will require recalibration in order that the inverted scale will read correctly, but this will be necessary in the majority of cases.

The A.V.C. line, in Fig. 10, is shown provided with a switch to give A.V.C. On and Off. If, desired, however, this switch can be expanded to

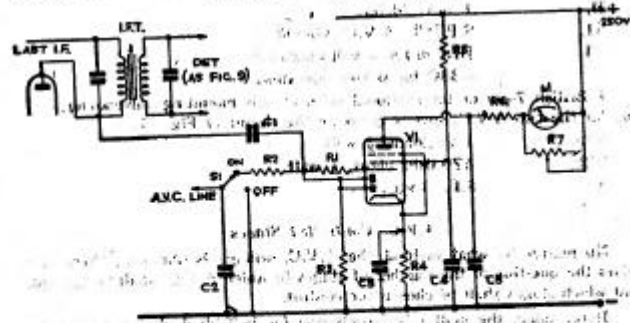

FIG. 10. A.V.C. and "S" meter Stage.

give A.V.C. Fast, A.V.C. Slow, and A.V.C. Off, the time constant of the resistance-capacitance combination C2, R2, being made variable by providing more than one resistance in the R2 position, such an arrangement being shown in Fig. 11.

A slow A.V.C. action is desirable when the receiver is to be used on programme transmissions, and is also useful for use on C.W. transmissions. A fast A.V.C. action, when code is being received, will tend to give fluctuations of the noise level between the code characters, but a slow action will "hang over" between the characters so that the A.V.C. is usable in that case with C.W. transmissions. A fast A.V.C. is also useful on rapid fading, however, so that if two positions are provided as in Fig. 11, the slow position using a 1 megohm resistance, the fast position using a  $\frac{1}{2}$  megohm resistance.

The A.V.C. diodes are shown as being fed through a small condenser from the anode of the last I.F. amplifying valve, so that the A.V.C. is taken off before the B.F.O. has effect, but as has already been shown, the diodes may be connected in at a previous stage.

**Components List for the A.V.C. "S" Meter Stage, Fig. 10.**

- |             |  |
|-------------|--|
| C1,         | 50 mmfds. Silver Mica.                                   |
| C2,         | 0.25 mfd. 350 v.w. Non-inductive.                        |
| C3, C4, C5, | 0.1 mfd. 350 v.w. Non-inductive.                         |
| R1, R2,     | 1 megohm, $\frac{1}{2}$ watt.                            |
| R3,         | 750,000 ohms, $\frac{1}{2}$ watt.                        |
| R4,         | (For 4 volt operation) 330 ohms, $\frac{1}{2}$ watt.     |
| R4,         | (For 6 volt operation) 390 ohms, $\frac{1}{2}$ watt.     |
| R5,         | 68,000 ohms, $\frac{1}{2}$ watt.                         |
| R6,         | 4,700 ohms, $\frac{1}{2}$ watt.                          |
| R7,         | 100 ohms, variable, wire-wound.                          |
| M,          | 1 mA. Meter.   |
| S1,         | S.P.D.T. A.V.C. On-Off.                                  |
| V1,         | DDPn for 4 volt operation.<br>6B9C for 6 volt operation. |
- 1 British 7-pin or International octal chassis mounting valveholder.  
Or, for the two A.V.C. speeds given by the circuit of Fig. 11,  
R2a, 1 megohm,  $\frac{1}{2}$  watt.  
R2b, 470,000 ohms,  $\frac{1}{2}$  watt.  
S1, S.P. 3-way.

**A.V.C. Controlled Stages**

No matter by what method the A.V.C. voltage is obtained, there still arises the question of the number of stages to which A.V.C. shall be applied, and which stages shall be chosen for control.

Here, again, the matter is largely one for individual choice, and if the "S" meter is fed from the A.V.C. line direct via a pentode, in the manner

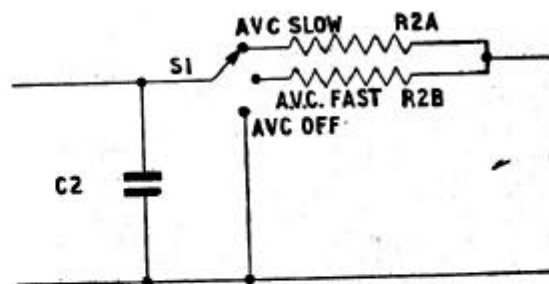

FIG. 11. A variable A.V.C. arrangement.

just shown, considerable latitude in the choice of the stages for control is possible. If the receiver is to be used for programme work on a local station as well as for distant contacts and listening, the local station will call for a fairly high number of controlled stages to prevent overloading, but if there are no strong signals at the receiver location, then control of two stages only in the receiver will be satisfactory.

In the first place it is wise to leave the R.F. stage uncontrolled, in order that it may work "full-out" and since this stage has the first manual control in its cathode circuit, it should be possible to prevent overloading of the input stage by the use of this control alone. The R.F. stage, therefore, will be left free of control, which may be applied to the frequency converter as the first valve in the controlled chain.

If control is also applied to the first I.F. stage, leaving the second stage clear, these two valves, converter and first I.F., should then exercise sufficient control over the rest of the receiver for all ordinary purposes.

When the receiver is to be used alongside a transmitter, however, the situation is different, and in this case not only should the R.F. stage have A.V.C., but it should also be possible to switch in a high bias line, supplying a negative bias from a subsidiary pack or battery. By using a high bias in this manner the station receiver may be used as the 'phone monitor or C.W. monitor even with the input shorted to earth, since in the majority of cases sufficient R.F. will break through when the transmitter is at the same or a near frequency. Making the high bias adjustable will give a manual volume control on the station transmitter monitoring, and the set, instead of idling when switched to Standby, or Transmit, will still be performing a useful task.

The controlled chain of valves in this case may well be the R.F. stage, and both I.F. stages, leaving the frequency-changer clear, the high bias, of course, being applied only to the R.F. stage, the signal from the station transmitter thus being attenuated in this stage alone, the rest of the receiver working normally. The arrangement of a high bias line will be shown in Chapter 6, and a suitable pack in Chapter 7.

### The "S" Meter

Whilst there are many advantages in connecting the "S" meter to its own individual valve, this is not economical when the A.V.C. voltages are supplied from a diode of the double diode detector-A.V.C. valve, and the meter in this case will be connected into the I.F. section so that it is operated by the changing anode current of the A.V.C. controlled valves.

The simplest connection is to feed the whole I.F. amplifier with current from the main H.T. line through the "S" meter, or, if a low current meter is used, one valve is fed through the meter.

The "S" meter is shunted by a wire-wound variable resistance of, say, 1,000 ohms. The meter is then set to the zero position by allowing the I.F. amplifier to work at full output with no signal applied to the set, the variable shunt across the instrument then being adjusted to give a full-scale deflection. When signals are passed through the receiver, the A.V.C. line switched into action, the rising bias with a rising signal strength reduces the anode current through the meter so that the pointer deflection is reduced. Here, again, there is the disadvantage that unless a right-hand zero instrument can be obtained the meter must be mounted upside down, the scale being recalibrated to suit the new conditions.

In Fig. 12 is shown a bridge circuit in which the "S" meter works in a straightforward manner, since the pointer deflection increases with signal increase.

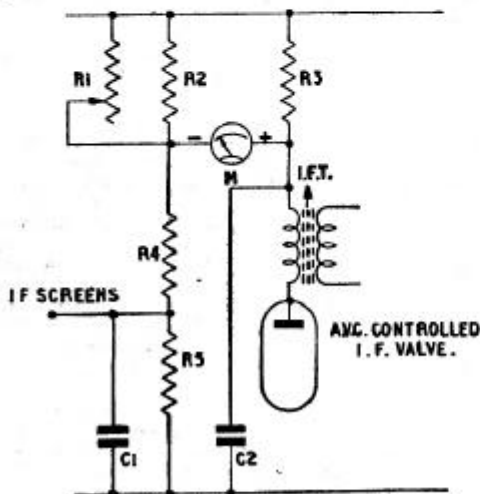

FIG. 12. Bridge Circuit "S" meter.

28

The bridge action occurs between the current flow in the anode circuit, which is liable to change with signal strength, and the current flow in a voltage-divider through which are supplied the screens of the I.F. valves. Since it is necessary for the current through the screen arm of the bridge to be very similar in value to the maximum current through the anode arm, the voltage-divider must be adjusted to give such a current, taking into account both the current through the valve screens and that flowing through the divider itself.

To set the "S" meter when this bridge circuit is used, the I.F. amplifier is set for full output with no signal applied to the receiver, the meter being set to zero by R1. The pointer indication will then rise when signals are allowed to pass.

#### Components List for the "S" Meter Circuit, Fig. 12.

R1,	1,000 ohms, variable, wire-wound.
R2,	330 ohms, $\frac{1}{2}$ watt.
R3,	270 ohms, $\frac{1}{2}$ watt.
C1, C2,	0.1 mfd. 350 v.w. Non-inductive.

NOTE.—The values of R4 and R5 depend, as has already been shown, on the current flowing to the screens of the I.F. valves, and upon the maximum anode current through R1. To take a concrete example, the maximum current for a 6K7 used as a controlled I.F. valve in the anode circuit is approximately 10.5 mAs. Thus, 10.5 mAs. must flow through R1-R2 and R4. Supposing that a pair of 6K7's are used in the I.F. amplifier, the screens will require a total of approximately 5 mAs. at 100 volts. Thus, for a pair of 6K7's, suitable values would be:—

R4,	15,000 ohms, 2 watt.
R5,	22,000 ohms, 1 watt.
M,	0.1 mA. meter.

The calibration of the "S" meter is also, unfortunately, a matter of individual choice. "S9" has yet to be given a definite value, although in certain commercial receivers "S9" indicates either a 50 or 100 microvolt input to the aerial sockets. Presuming that "S9" indicates an input of 100 microvolts, however, it must not be supposed that the receiver is therefore standardised, for the connecting of a pre-selector or v.h.f. converter between the aerial and the receiver will throw the "S" meter completely out of calibration since there will now be the gain of the new unit to take into account, whilst in actual fact the "S" meter gives a true reading only at the frequency, and with the input conditions, that obtained at the time of calibration.

Moreover the noise level of the receiver will affect the "S" meter when no signal is being received, so that it would probably be more accurate to give signal strength as points above "S1" rather than above "S0." Again, the "S" meter gives an indication which may be affected not only by the manual gain control of the R.F. stage but also by any gain control or controlled regeneration control fitted to the I.F. amplifier. Thus, for comparison between stations the "S" meter is not of real value, although its readings are often quoted—the real value of an "S" meter is to judge the effect of adjustments made at the distant transmitter, or to show the

29

gain obtained from the use of a different transmitting aerial, or to show the effect on a distant station of fading or similar variable conditions. For station reporting, also, the true way to use the "S" meter is to take a noise reading on the station channel with the station off, and a second reading with the station on, thus obtaining a reading which is the difference between the station level and the noise level, the report being given as number of decibels or "S" points above noise. The "S" meter is also of great use for checking the radiation patterns of aeri-als—rotating aeri-als, used at the transmitter, the "S" meter readings being noted whilst the transmitting aerial is turned through a whole revolution, the readings being plotted against rotation. Such tests should, of course, be made between transmitters and receivers located close one to the other, since such tests conducted over a distance give meaningless results due to fading which cannot be checked.

The nine points on an "S" meter are generally separated by 6-decibel spacings; that is, between each "S" point and the next there are six decibel points. Since six decibels corresponds to a doubling of voltage, this means that each successive "S" point indicates, or should indicate, that the signal voltage at the aerial terminals has been doubled.

The "S" meter may be calibrated, therefore, by the use of a signal generator with a calibrated microvolt output scale, "S9" being set at a known level and the points calibrated down in terms of decibels, each point indicating double the input of that required to give the point below it.

If a signal generator with calibrated output is not available, probably the most satisfactory calibration will be given by printing points on the scale showing the same degree of rise as that already suggested, the calibration being made against a good moving coil instrument. The "S" meter will then be an indicator with an unknown reference level.

A third method of calibration is to style the half-full-scale-deflection point of the meter "X," with points above and below this calibrated as 2X, 3X, 4X, etc., and  $\frac{1}{2}X$ ,  $\frac{1}{3}X$ , etc., so that the scale, although once again calibrated to an unknown reference point, can give readings against X of standard gains or losses. This is done by bringing the "S" meter deflection to X on any received station by the use of the R.F. or I.F. manual gain control, fading or station adjustments then showing on the meter.

#### The Noise Limiter

Of the various noises which may be received along with the desired signal, the most troublesome is impulse noise, such as is caused by the ignition system of cars. A circuit which would remove the noise entirely whilst passing the station signal would be extremely difficult to devise, but it is found that when noise is troublesome its amplitude is invariably much greater than the signal amplitude, so that limiting the noise amplitude down to the signal amplitude effects a simple and very effective cure.

Several noise limiting circuits are available to the constructor, some working on the audio amplifying stages and some in the detector stage, but the simplest limiter, with adjustable and controlled action, is the series-diode circuit.

A diode is biased from a voltage-divider circuit between the positive and negative H.T. lines in such a fashion that a signal of high amplitude, presented to the valve, renders the diode non-conducting for the duration of the signal, signals of smaller amplitude being passed without causing this action. The diode thus "chops" peaks of noise which, being of short duration thus cause "holes" in the audio signal which are barely noticeable, so that signals can be read through ignition and similar impulse interference.

The biased diode is placed between the detector and the audio gain control, and may be used with either diode detectors or detectors such as the infinite impedance type. The two circuits to be used are shown in Figs. 13a and 13b.

If necessary or desirable, the noise limiter can be switched out of action by a D.P.D.T. switch, one position of the switch placing the limiter in circuit, the other position switching out the limiter and passing the signal straight to the audio gain control.

A slight drop in audio output is consequent upon the use of a limiter, but this can be masked with the audio gain control.

The level at which the chopping action takes place is set by the bias applied to the diode through the control potentiometer R5 in Figs. 13a and 13b, and this is adjusted on a signal until distortion commences. The control is then backed off slightly to clear the signal of distortion, and will then limit noise with a higher amplitude than that of the signal. The limiting control must, of course, be readjusted for signals of varying strength although the levelling action of A.V.C. is of help in this instance.

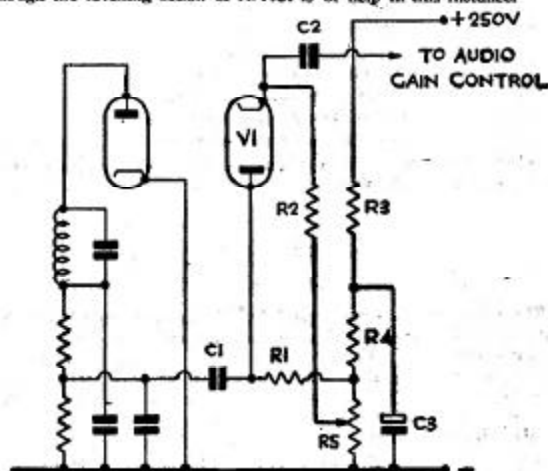

FIG. 13A. Diode Noise Limiter with Diode Detector.

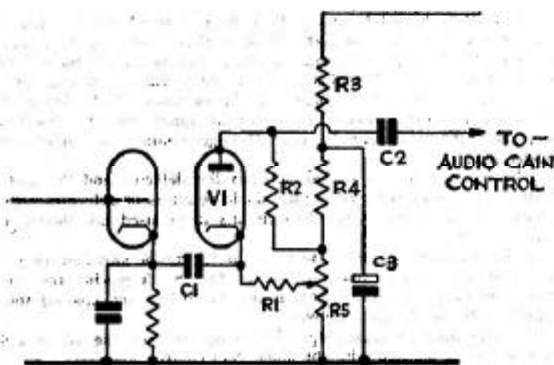

FIG. 18a. Diode Noise Limiter with Infinite Impedance Detector.

**Components List for the Noise Limiter, Figs. 18a and 18b.**

R1,	220,000 ohms,	$\frac{1}{2}$ watt.
R2,	47,000 "	$\frac{1}{2}$ "
R3,	33,000 "	$\frac{1}{2}$ "
R4,	39,000 "	$\frac{1}{2}$ "
R5,	10,000 ohms	variable.
C1, C2,	0.1 mfd.	350 v.w. Non-inductive.
C3,	8 mfd.	350 v.w. Electrolytic.
VI,	D1, DD41, etc.,	for 4 volt operation.
	6H6, etc.,	for 6 volt operation.

When using a double diode, the anodes and cathodes may be strapped in pairs to give a single diode.

**CHAPTER 4**

**THE CRYSTAL FILTER**

The crystal gate, as the crystal filter is popularly called, may be included in the I.F. amplifier of the communications receiver to give an I.F. response curve shaped either as a single peak, this peak being steep-sided and narrow, indicating sharp selectivity and rapid fall-off of response to either side of the central frequency, or by the use of a pair of crystals, as a double-peaked bandpass response with sharp cut-off sides and a region on either side of the pass-band of zero response.

The crystal or crystals used in such a filter are cut from quartz, as is the ordinary oscillating crystal used for frequency stabilisation, the crystal-

cut being so made that the filter crystal resonates at or very near the I.F. used in the receiver. A crystal so cut acts as a tuned circuit of very high Q or efficiency, this tuned circuit efficiency being very much higher than can be achieved by the use of an I.F. transformer, the selectivity also being improved to a value which could only be obtained by a multiplicity of I.F. stages were no crystal to be used.

Not only is the greater selectivity of the I.F. amplifier useful in giving a "single signal" effect, or in assisting the rejection of signals a few kcs. off the resonance point, but the sharp response curve also improves the signal-to-noise ratio as far as the I.F. stages are concerned, since noise level is cut with the cutting of the pass frequencies.

The crystal filter is used as a coupling between stages in the I.F. amplifier, the selectivity introduced by the coupling being variable and under control when the single crystal is used. The term crystal "gate" really refers to single crystal working.

There are differing advantages and disadvantages obtained by the use of either single or double crystal working, but it is felt that the single crystal filter will be most suitable for the majority of amateurs, especially when the receiver is being home-constructed. The double filter, giving as it does a narrow band-pass action, is excellent for C.W. work, but is not open to such simple variable selectivity adjustment as is the gate, whilst the crystal expense is doubled. For telephony, a pair of crystals separated by a few kcs. must be used, and for C.W. a pair of crystals separated only by 300 or 500 cycles is used, so that the crystal expense rises by reason of both the extra crystal and the accuracy of the cut required. Whilst tuning is simpler when the band-pass arrangement is adopted, since the I.F. response curve is a flat top instead of the single crystal peak, the variable selectivity obtained by the use of the simpler gate circuit minimises tuning troubles and is more suited for non-specialist working.

The basic essentials for crystal gate operation are simple and the action quite easy to understand. A crystal acts as a tuned circuit of extremely high efficiency at its resonant point (the equivalent electrical circuit being a series-tuned rather than a parallel-tuned circuit), the impedance of this tuned circuit being very low at the resonant point but rising very rapidly on either side of resonance to practically infinity. A crystal, acting as a coupling between two I.F. amplifiers and cut to resonate at the intermediate frequency — say, 465 kcs. — will thus provide very good coupling characteristics at the I.F., but will reject signals a few kcs. off the central frequency.

A crystal, however, cannot be used alone. In the first place, it must be supported in a crystal-holder, and the plates of this component act as a small capacitance which will pass to some degree the frequencies which the crystal is rejecting, whilst at the same time the crystal will have an impedance which requires matching not only to the stage feeding into it but also to the stage following the filter. At the same time, it is necessary to arrange a small degree of feedback, in a circuit similar to a neutralising circuit, to offset the disturbing capacitance of the crystal-holder's plates, this small feed being 90 degrees out of phase with the feed through the stray capacitance.



Accordingly, to supply all these requirements, the crystal circuit is fed from a special I.F. transformer with a centre tap to earth, this centre tap being either an actual connection at the centre of the coil or supplied as an electrical centre tap by a pair of condensers across the secondary of the transformer, their junction being earthed to the chassis.

This arrangement is shown in Fig. 14, where the secondary of the first transformer is actually centre-tapped.

The effectiveness and efficiency of the crystal gate depends to a very large degree upon the following impedance which, in Fig. 14, is supplied by the following transformer and valve. As the impedance  $Z$  of this circuit rises, so will the signal voltage developed across the impedance rise, but this has the effect of reducing the apparent  $Q$  of the crystal circuit and thus of reducing the selectivity.

By varying the impedance of the circuit following the crystal, it is therefore possible to obtain the variable selectivity effect which is so desirable for use on different types of signals. In this respect the crystal gate is superior to the double crystal band-pass filter. The input circuit, however, can have the same effect on the selectivity, and in practice it is usual to connect the variable selectivity control into the crystal input circuit, detuning of the input circuit by a condenser giving higher selectivity.

It will be seen that special transformers are necessary for use with a crystal filter, and in Fig. 14 the second tuned circuit, which is acting as an auto-transformer, must be tapped to match the crystal impedance. This state of affairs is further complicated by the fact that two types of crystal are in use, the Y-cut crystal as used in American receivers, having a low impedance, and the X-cut crystal, more often used in British receivers, having a high impedance. By the use of an X-cut crystal, however, and by using a circuit

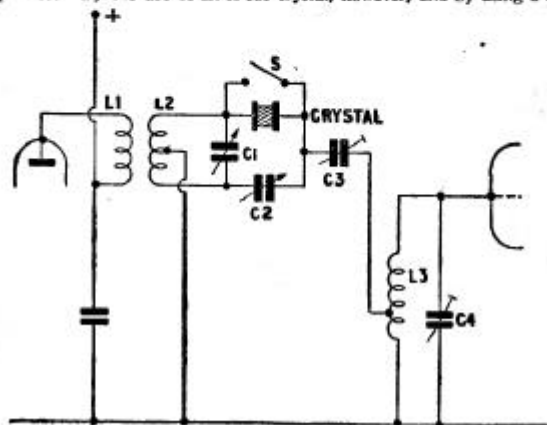

FIG. 14. The Crystal Gate Circuit No. 1.

with high input impedance to follow the second tuned circuit, the tapping on L3 can be dispensed with and the crystal filter connected to the top end of the tuned circuit.

C2 in Fig. 14 is the variable condenser used to balance out the stray capacity of the crystal-holder, and is termed the "phasing" condenser. When the phasing condenser is set to balance the circuit, the response curve of the filter is symmetrical, but if the phasing condenser is varied to a small degree on either side of the balancing value, the symmetry of the response curve is lost and a point of zero signal voltage occurs on either the high or low side of resonance, this point of zero signal approaching or receding from the central frequency as the phasing condenser is varied in capacitance. By this means, therefore, true single-signal reception is possible since the zero response point can be adjusted to fall on an interfering signal. The response at the opposite side of the response curve rises, however, so that it is possible to introduce interference from a third signal whilst cutting out interference from a second, but in general the benefits given by the zero signal point are very well worth while.

The selectivity, even at the minimum position, given by the filter circuit of Fig. 14 is sufficiently high to make tuning on a telephony transmission so sharp that considerable sideband cutting ensues, and so a switch across the crystal may be provided to cut the filter out of action.

Fig. 14 may be changed from the crystal gate to the band-pass crystal filter circuit by connecting a second crystal across the phasing condenser C2, this second crystal being separated in frequency from the first crystal by the bandwidth frequency it is desired to pass. C2 may then require some decrease in value to deal with the new balance point.

In Fig. 15 is shown a crystal gate with a wider range of selectivity control, the control itself also being simpler since a variable resistance is used on the output side of the filter. An input transformer matched to the crystal impedance is used, whilst phasing is now carried out by means of a differential condenser. The input coil L2 is centre-tapped electrically rather than physically by the use of a pair of condensers.

The output tuned circuit must have a high  $Q$ , and the selectivity control, R1, may be variable either smoothly or in steps, a set of resistances connected to a switch being used in the latter case. L3 and C4 must, of course, be capable of tuning to the I.F. in use.

The main difficulty attached to the incorporation of a crystal gate in a home-constructed receiver lies, therefore, in the provision of a suitable input transformer for the filter, for if a crystal is obtained as a separate component its characteristics must be known before a transformer matched to its impedance can be bought or made. Moreover, the transformer characteristics depend upon the filter circuit used. In Fig. 14 the transformer requires a high inductance primary with a secondary tightly coupled to it, whilst L3 must be tapped at a suitable point unless a high input impedance valve circuit is used to follow the filter.

In Fig. 15 a step-down ratio is needed in the input transformer, at least for some crystals, whilst a high  $Q$  tuned circuit must follow the filter.

The filter will, of course, work with a mismatched transformer and give high selectivity, but the loss of gain over the filter will be very serious. Even

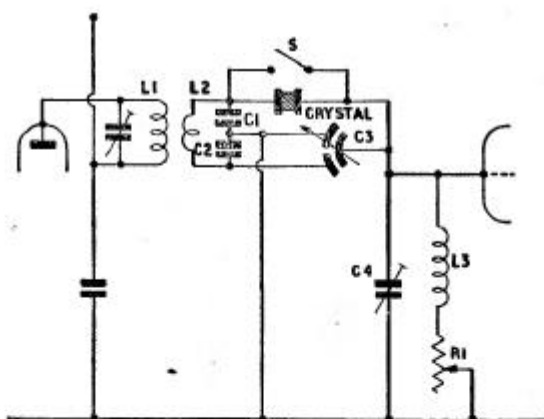

FIG. 15. The Crystal Gate Circuit No. 2.

with correct matching there is a loss, real or apparent, in the gain over the filter—the higher selectivity will, at best, cause an apparent drop in gain by reducing background noise and signal sidebands—but when two I.F. stages are provided, there will be gain in hand to compensate for this loss.

The wisest plan, therefore, would appear to be the buying of a complete crystal filter unit for incorporation in the receiver, when it would be known that the I.F. transformers were properly matched to the crystal, or the transformers and crystal may be obtained as matched components, and the unit built up with its associated condensers, but the experimenter may care to test various transformers against his crystal in an endeavour to obtain a filter at the lowest cost without loss of efficiency.

In this case it is advised that tests be made using the circuit of Fig. 15. The input transformer may be made experimentally from an old I.F. transformer of the correct frequency—465 kcs. is advised—the secondary winding being stripped of half its turns. The centre tap being electrical, further experiment can be carried out on this winding until the most favourable results are obtained with the crystal to be used.

The phasing condenser can be made by mounting two midge tuning condensers together, their spindles being coupled via a coupling unit so that with one condenser at full mesh the second condenser is at zero mesh, or minimum capacitance.

The high Q circuit of L3-C4 may be one side of an efficient I.F. transformer, or a pre-tuned I.F. rejector coil of the iron-cored variety might be tried in the position.

The type of crystal obtained will govern the circuit constants to a high degree.

The position of the crystal gate in the I.F. amplifier depends to some extent on the following circuit, and in this connection the infinite impedance detector makes an excellent following stage to the filter. The gate is often shown immediately following the frequency-changer, but since the filter requires a fairly high input signal for its most efficient operation, it is wise to allow for some I.F. amplification prior to the filter. The Q of the tuned circuit L3-C4 in Fig. 15 will be assisted by an infinite impedance detector, and so, when such a detecting stage is used, the obvious place for the filter is between the I.F. amplifier and the detector. Where diode detection is used, however, the filter may be used as the coupling between the two I.F. stages.

*Components List for the Crystal Gate, Fig. 14.*

L1, L2,	High inductance — close-coupled I.F. transformer, C.T. secondary.
L3,	I.F. coil, tapped down to suit crystal.
C1,	100 mmfd. variable. Selectivity control.
C2,	15 mmfd. variable. Phasing control.
C3,	60 mmfd. variable trimmer.
C4,	I.F. tuning trimmer.
Crystal,	465 kcs.
S,	Crystal shorting switch. (Low capacity type, with short leads to crystal.)

NOTE.—To experiment with this circuit, use a high impedance or X-cut crystal and dispense with the tapping on L3 by using an infinite impedance detector as the following stage. Adapt L1, L2, by using an I.F. transformer with coils mounted on a central dowel, moving the secondary coil close to L1 and mounting, on the other side of L1 and at the same distance, a second secondary coil identical with that already fitted, obtained from a second similar transformer. These two secondaries are then connected in series, thus providing a high inductance centre-tapped winding.

Test L1 both with a trimmer condenser in parallel and without.

*Components List for the Crystal Gate, Fig. 15.*

L1, L2,	Tuned primary — low impedance secondary I.F. transformer.
L3,	High Q I.F. coil.
C1, C2,	0.0001 mfd. Mica.
C3,	10 mmfd. Differential. (See text.)
C4,	I.F. tuning trimmer.
R1,	5,000 ohms variable. Selectivity control.
Crystal,	465 kcs.
S,	Crystal shorting switch. (Low capacitance type with short leads to crystal.)

In either circuit the whole filter is cut out of action by the switch across the crystal, leaving the I.F. amplifier working at its normal selectivity.



CHAPTER 5

THE BEAT FREQUENCY OSCILLATOR

The B.F.O. is a simple oscillating circuit working on a frequency close to the intermediate frequency of the receiver, a fraction of its output being fed to the I.F. amplifier or, preferably, the detector. This locally generated frequency then heterodynes any signal passed to the detector from the I.F. amplifier so that signals which are not modulated, such as C.W. transmissions, are given an audio content, the heterodyne frequency being in the audible range. The coil used, together with a small trimmer type tuning condenser, as the oscillating tuned circuit is usually tapped near the earthed end in order that a Hartley oscillator circuit arrangement can be used, such a circuit being both economical in components and very stable.

Either a pentode or triode valve may be used as an oscillator, the choice of types being very wide, and typical circuits and components values are given in the Figs. 16 and 17 with their associated components lists.

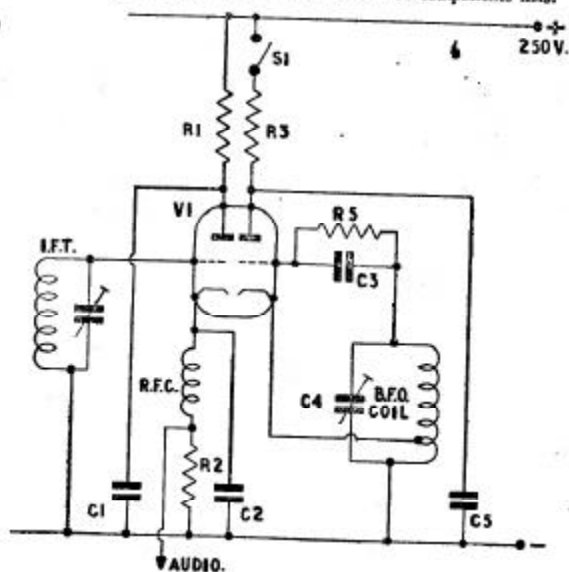

FIG. 16. A B.F.O. and Impedance Detector.

In Fig. 16 the B.F.O. is shown as one-half of a double triode valve, the second part of the valve acting as an infinite impedance detector. This form of construction is excellent in that the coupling from the B.F.O. to the detector takes place within the valve itself, via stray capacities, so that no further coupling is required. Unfortunately, this type of circuit can be used only with American valves of the 6F8 type or similar, since there are no 4-volt double triodes suitable for the purpose.

The infinite impedance detector in this circuit is shown as being of slightly different design from that described in Chapter 3, since filtering in the cathode circuit is assisted by the choke, R.F.C., which, of course, should be effective at the intermediate frequency.

Separate triodes can, of course, be used with the same component values to give equivalent operation, a small coupling condenser then being used between the grids of both valves as Cc of Fig. 17. The condenser Cc has a very small value of capacitance, and may be made either by removing the adjusting screw of a 30 mmfd. trimmer and bending the top plate at an angle to the bottom plate, thus providing the small capacitance required, or by wrapping a lead from the grid of the B.F.O. round the grid lead of the detector (or the anode lead of the detector if a diode detector is used), both leads being insulated.

Components List for the Combined Impedance Detector and B.F.O., Fig. 16.

R1,	22,000 ohms,	$\frac{1}{2}$ watt.
R2,	150,000 "	$\frac{1}{2}$ "
R3,	10,000 "	$\frac{1}{2}$ "
R5,	47,000 "	$\frac{1}{2}$ "
C1, C5,	0.5 mfd. 350 v.w.	Non-inductive.
C2, C3,	0.0001 mfd.	Mica.
C4,	150 mmfd.	variable trimmer.
B.F.O. coil,	Wearite B-FO	or similar.
R.F.C.,	Choke, Eddystone 1066	or similar.
S1,	S.P.S.T. B.F.O.	On-Off switch.
V1,	6F8.	
1 International octal chassis mounting valveholder.		

NOTE.—Several 4-volt valves may use the same B.F.O. circuit, for a separate detector-B.F.O. arrangement. The AC2HL or 354V oscillate well, an MHLA or 224V being used as the Infinite Impedance detector.

Components List for the Pentode B.F.O., Fig. 17.

C1, C3,	0.0001 mfd.	Mica.
C2,	150 mmfd.	variable trimmer.
C4,	0.1 mfd.	350 v.w. Non-inductive.
C5,	0.5 mfd.	350 v.w. "
R1,	68,000 ohms,	$\frac{1}{2}$ watt.
R2,	15,000 "	1 "
R3,	10,000 "	1 "
B.F.O. coil,	Wearite B-FO	or similar.

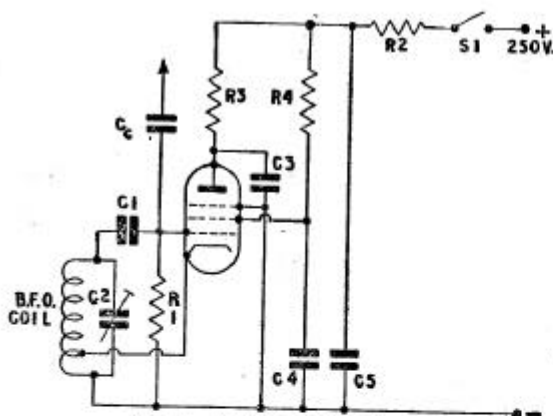

FIG. 17. A Pentode B.F.O. Circuit.

S1, S.P.S.T. B.F.O. On-Off switch.  
V1, VP41, etc., for 4 volt operation,  
6K7, etc., for 6 volt operation.

1 Mazda or International octal chassis mounting valveholder.  
NOTE.—C<sub>c</sub>, small coupling condenser to detector. See text.

To adjust the B.F.O. the receiver should be tuned to a C.W. signal of moderate strength, the B.F.O. being switched off whilst the signal is tuned sharply, the tuning being on the carrier hiss. The B.F.O. is then switched on and tuned to give a suitable beat note with the signal code, the receiver tuning being left untouched whilst the B.F.O. tuning is carried out.

The B.F.O. is then set for all C.W. signals.

In circuits where the B.F.O. feeds into a diode detector and A.V.C. stage the A.V.C. line should be switched off for C.W. reception. Where the A.V.C. valve is fed from the I.F. amplifier before the introduction of the B.F.O. carrier, however, the A.V.C. line may be left on for C.W. reception providing that a "slow" A.V.C. action is obtainable.

## CHAPTER 6

### PRACTICAL RECEIVERS

Within the following pages are shown the circuit diagrams, with components lists, of a series of practical communications receivers. The circuits include both simple and more complicated designs, the simpler circuits being included on the strength of the fact that even though they are less versatile than their companion receivers they are still of great value as true "com-

munications" receivers in that they will amply fill the role of listening-post at either the transmitting station or short-wave receiving station.

Whilst the simpler circuits may have two-control tuning—i.e., separate tuning of the oscillator and aerial-tuned circuits—to enable the coils to be home-made and tracking to be adjusted without the use of trimming and padding, the more complicated receivers require to have ganged tuning if all the benefits of the more comprehensive circuits are to be realised.

The writer's experimental work has shown that for full coverage of, say, 5 or 10 to 2,000 metres, the work involved in building and especially in adjusting and tracking home-made coils is too fine and time-consuming for the home workshop. The value of home-made coils must lie in their simplicity, and so two systems of receiver-tuning are shown. For receivers intended to cover the amateur bands only, home-wound coils are shown, with their winding details, and separate aerial and oscillator tuning is employed. The coils are wound and the tuning capacitances are chosen in such a manner that each coil covers the band for which it is specified, the inter-amateur band frequencies not being covered. By this means, those requiring amateur reception are catered for, the circuits being both selective and easy to tune.

To cover the whole frequency range, however, larger condensers must be used to avoid a great multiplicity of coils, and accordingly commercially-made coil sets are specified. Since these coils are intended to be tuned by ganged condensers of 0.0005 mfd. capacity or similar, bandspreading provision is made so that at any frequency the main tuning gives way to fine tuning whenever necessary. In this way all frequencies are received and at the same time the crowded bands are "opened out" to a very considerable extent.

A communications receiver of any type must be constructed with great care, since the number of stages working at radio and intermediate frequencies increases the possibility of feedback, especially where such stages are made regenerative. The receiver layout should follow in logical steps, the R.F. stages being grouped to one side of the tuning condenser assembly or assemblies, each stage opposite its own section of the condenser, with the I.F. amplifier following the mixer stage in line, the transformers being mounted between the valves wherever possible, since the transformer screening then assists the valve screening. It is wise to provide external valve screens for all the R.F. and I.F. stages, but if this is thought unnecessary the receiver may be tested without extra valve screening, the screens being added later if there should be any trace of instability.

The circuits shown all include extensive decoupling for each stage.

All the receivers should be built on aluminum chassis. A copper chassis might be even more suitable, although the extra efficiency so gained is insufficient to give any noticeable result, but steel or iron chassis should be avoided since losses with such material at the higher frequencies are high.

Chassis layout, and especially panel layout, must be clean and symmetrical. Where both main tuning and bandspread tuning is used, both sets of condensers should have a good slow-motion drive, and it is advised that drives of the panel dial variety with cards for individual calibration mounted in an escutcheon should be used. Two methods of calibration are possible. For the general listener, the bandspread dial need not be calibrated,

for the bandspread condensers should be set to half capacity and all exploration work carried out on the main tuning condenser control. The bandspread condensers are then available for expansion of the main tuned frequency, the main dial being calibrated in terms of frequency or wavelength.

The amateur transmitter, however, might well use the reverse of this technique, calibrating the main tuning dial to show band limits with the bandspread condenser at half mesh, the bandspread tuning dial itself being calibrated in terms of each band.

Only in the smaller receivers should the power pack be included in the receiver cabinet, although when A.C./D.C. arrangements are shown this type of power supply may also be included with the receiver, since the chassis space taken up is small and the power supply can be grouped well to one end of the chassis, provided that ample ventilation is provided. In general, however, even with a small and simpler receiver, the heat generated by the power unit should be kept from the set to minimise the chance of frequency drift with temperature.

For battery operation, vibrator power supplies must be used, and here the builder is advised to obtain the vibrator power pack commercially, such a pack as the Masteradio "Silent Surge" type, specially designed for communications and similar work, proving highly suitable. In the next chapter, however, the circuit of a vibrator power pack is shown.

It will be noted that in the majority of diagrams two H.T. lines are shown, one running at the anode line voltage of 250 volts, the other at the screen voltage of 150 volts. The provision of two lines, one for screen operation, saves a considerable outlay on screen dropping resistances, as well as making screen decoupling simple.

The receivers are shown with straight I.F. amplifiers—that is, no crystal gate is shown. It is felt that the majority of constructors will be content with the selectivity obtained from the use of a regenerative I.F. stage alone, and that if a crystal gate is to be included in the circuit the details in Chapter 5 will enable the work to be carried out without trouble.

#### Receiver Alignment

The alignment of the communications receiver must be carried out with great care, and a signal generator is essential. Procedure is as follows:—

Switch on both receiver and generator, and allow them to reach operating temperature—a time of ten minutes at least should be allowed.

Whenever possible, the receiver should be connected into an output meter, either of the Magic Eye type or the "Output Meter" sockets of a good circuit analyser. The first alignment is, of course, on the I.F. amplifier, so that the "S" meter of the receiver, if fitted, may be used as the output meter, the A.V.C. line in this case being left switched on. The usual practice, however, is to align the set with the A.V.C. line switched off, since the alignment should be made with the receiver running at maximum gain, so that in the case of a separately-fed "S" meter, such as that shown in Fig. 10, the A.V.C. line may be off, so far as the receiver is concerned, whilst the meter will still operate, with enhanced sensitivity.

The B.F.O. should be switched off for all alignments, whilst the crystal gate, if fitted, should be switched out of circuit. Clip the earth lead of the

signal generator to the receiver chassis and take the signal lead from the generator to the grid of the last I.F. amplifier and set the generator to the required I.F.—465 kcs. for the circuits shown. Trim the last I.F. transformer to give maximum output, reducing the generator signal as the circuit comes into tune. With this transformer set, re-connect the signal lead from the generator to the grid of the first I.F. stage, and trim the next-to-last I.F. transformer for maximum output in the same manner. (Further I.F. stages following the frequency converter should be trimmed in turn, working back always to the frequency converter; this applies to a commercial receiver using several I.F. stages.)

To align the first I.F. transformer, connect the signal lead from the generator to the signal grid of the frequency converter, disconnecting the tuned circuit allied with the frequency converter should the signal passed to the I.F. amplifier appear very weak. This will be caused by a high-frequency circuit acting almost as a short circuit to the considerably lower frequency output of the generator. The output from the generator must be kept at a low level when feeding into this stage, however, since the I.F. amplifier is now tuned and will be giving a high gain to the signal, so that overloading must be prevented.

If a crystal gate is incorporated in the I.F. amplifier, the alignment should be carried out up to the frequency converter stage as already described, the I.F. as set by the signal generator being as near as possible to the exact crystal frequency. The crystal gate is then switched into circuit, and the signal generator varied very slowly to a slight degree on either side of the set frequency. A rise in output from the I.F. amplifier as the generator frequency is slowly varied indicates that the crystal peak has been found, and the generator should be left at the frequency causing the output rise, and connected into the frequency converter, whilst the I.F. amplifier is given a final adjustment to bring it to resonance with the crystal.

It is best to use an unmodulated output from the signal generator for aligning the I.F. amplifier when a crystal gate is in use, using the "S" meter indications on the generator carrier. If no "S" meter is fitted, the B.F.O. may be switched on and adjusted to give an audio signal at the output sockets of the receiver, alignment being carried out by bringing this audio signal up to maximum output.

The I.F. amplifier is now set, and should be left as it stands whilst the remainder of the receiver is aligned.

The procedure for aligning the R.F. circuits will vary with the type of receiver, for in the simpler separately-tuned aerial and oscillator type of set, where no R.F. stage is employed, no further aligning will be required, although the signal generator can be used very effectively to calibrate the two tuning dials.

The oscillator dial is the main tuner, in such a receiver, and signals should be tuned with this dial, the aerial tuner being kept roughly in step until the required signal is heard when the tuning can be finely adjusted. It will be sufficient, therefore, to calibrate the oscillator tuning dial in fairly close frequencies with broad frequency indications only on the aerial dial.

For a receiver employing ganged tuning, however, the oscillator circuits must be set for tracking, the adjustments being made on each frequency range by the following method:—

Set the bandspread condenser, if used, to mid-capacity and leave. Switch to the first frequency range, and reduce the oscillator trimmers to minimum capacity, leaving other trimmers and padders at half-capacity. Tune the main tuning condenser to the high frequency-low wavelength end of the band, either to a calibrated spot on the dial, or, if the dial is to be calibrated, at a point just above minimum capacity. Set the signal generator to the same frequency—this will require to be discovered by experiment if the exact coverage of the coils is unknown—and connect the signal lead from the generator together with the earthing clip to the aerial input sockets, or aerial and earth sockets, of the receiver. Trim the oscillator trimmer towards maximum capacity until the signal is heard or indicates on the output meter.

With the high frequency adjustment temporarily set, mark or note the dial reading of both receiver and generator, and then tune to the low frequency-high wavelength end of the band either to a frequency indicated on the receiver dial, or with an uncalibrated dial, to a frequency near the low frequency limits of the coils in use. Set the generator to the same frequency and adjust the padding condenser for maximum output at that frequency. Return to the original high frequency where the trimmer was adjusted. The adjustment will probably have varied, due to the changing of the padder capacity, and the trimmer must be readjusted for maximum output, this process of adjusting trimmer and padder, and readjusting being carried out until the two adjustments are in final balance. Six or eight readjustments are not too many.

This process must be carried out on each frequency band.

With the oscillator aligned, it remains to trim the R.F. stage, if included in the set, together with the frequency converter input circuit. The trimmers connected with these stages must be trimmed for maximum output at the high frequency end of each range, the whole range being tested, by means of the signal generator, at convenient points to ensure that no points of bad alignment or weak signals exist.

With the receiver aligned on all frequency ranges, it may be tested for correct operation and stability. A hiss, varying with the tuning of the oscillator stage, indicates that the oscillator is squegging, possibly because of too high a grid leak value or anode voltage, whilst instability causing oscillation in the I.F. amplifier is immediately shown when the B.F.O. is switched on, since a continuous squeal or howl is caused, the note varying with the tuning of the B.F.O. A regenerative I.F. stage should not, of course, have feedback sufficient to give this effect, and the feedback capacity between grid and anode should be reduced until the stage is regenerative without bursting into oscillation.

"Motorboating" is almost certainly due to the oscillator's fluctuating in frequency with slight variations of anode voltage, the chance of this defect occurring being highest with high selectivity in the I.F. amplifier. Switching out the A.V.C. line will probably stop the trouble, proving that the oscillator anode voltage is fluctuating and that the stage is varying its output frequency in sympathy. Only a poorly-designed oscillator would cause this trouble, which may be cured either by re-design of the oscillating circuit or a stabilising device on the oscillator H.T. supply line.

"Birdies," a heterodyne whistle or beat on a signal, are sometimes caused

by feedback into the I.F. amplifier via the A.V.C. diode, or by feedback of signal harmonics from the detector into the R.F. or frequency converter, or may be another sign of squegging in the oscillator. Generally the cure is better circuit arrangement or heavier screening.

It must be remembered, also, that a heterodyne note can be produced by a carrier close to that of the signal under reception, the crystal gate being the only solution to this nuisance.

#### Components List for a Simple 4-volt Receiver, Fig. 18.

C1, C9,	60 mmfd. Tuners. Raymart MC60X.
C2, C4, C6, C7, C10,	
C11, C15, C21,	0.1 mfd. 350 v.w. Non-inductive.
C3,	0.01 mfd. 350 v.w. Non-inductive.
C5, C12, C13,	
C17, C18, C19,	0.0001 mfd. Mica.
C8,	40 mmfd. Bandspread tuner, Raymart VC40X.
C14, C22,	25 mfd. 25 v.w. Electrolytic.
C16,	8 mfd. 350 v.w. "
C20,	30 mmfd. variable trimmer, "
R1,	2,200 ohms.
R2, R8, R15,	47,000 "
R3, R6,	220 "
R4,	10,000 "
R5,	1,000 "
R7,	5,000 variable. I.F. gain.
R9, R16,	220,000 ohms.
R10,	680 "
R11,	33,000 "
R12,	68,000 "
R13,	1 meg. variable. Audio gain.
R14,	22,000 ohms.
R17,	180 "
(All resistors $\frac{1}{2}$ watt ratings.)	
I.F.T.1, 2,	465 kcs. Iron-cored I.F.T.'s.
J,	Headphone jack.
R.F.C.,	Short-wave choke.
T1,	Output transformer, 5 watt, to match to 5,200 ohms load.
Arrange C <sub>1</sub> for regeneration over V <sub>2</sub> , and C <sub>2</sub> for coupling between V <sub>3</sub> and V <sub>4</sub> .	
S1,	S.P.S.T. B.F.O. On-Off switch.
L5,	Wearite B-FO.
V1,	ACTH1.
V2,	VP41.
V3,	ACHLDD.
V4,	AC2HL.
V5,	Pen 45.
2 British 7-pin chassis mounting valveholders.	

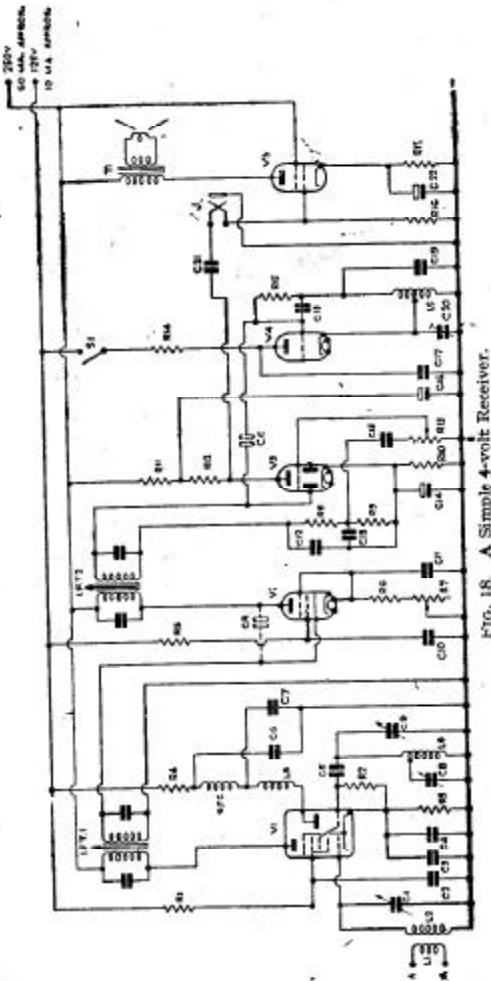

FIG. 18. A Simple 4-volt Receiver.

- 1 British 5-pin chassis mounting valveholder.
- 2 Mazda octal
- Chassis, aluminum, 10" x 8" x 2 1/4". "
- 1 Tuning Drive.

*Coil Data.*

1.75 mcs.—					
L1,	15	turns	26 S.W.G. enam.	close-wound,	1/4" above L2.
L2,	70	"	"	"	"
L3,	15	"	24	"	1/4" below L4.
L4,	42	"	"	"	Tap—Top of coil.
3.5 mcs.—					
L1,	9	"	"	"	1/4" above L2.
L2,	35	"	"	"	"
L3,	10	"	"	"	1/4" below L4.
L4,	25	"	"	"	Tap—18 turns up.
7 mcs.—					
L1,	5	"	"	"	1/4" above L2.
L2,	20	"	18	"	"
L3,	6	"	24	"	1/4" below L4.
L4,	14	"	18	"	to 1" long. Tap—6 turns up.
14 mcs.—					
L1,	5	"	24	"	close-wound, 1/4" above L2.
L2,	10	"	18	"	to 1" long.
L3,	4	"	24	"	close-wound, 1/4" below L4.
L4,	7	"	18	"	to 1" long. Tap—2 1/2 turns up.
28 mcs.—					
L1,	4	"	24	"	close-wound, 1/4" above L2.
L2,	4	"	18	"	to 1" long.
L3,	3	"	24	"	close-wound, 1/4" below L4.
L4,	3 1/2	"	18	"	to 1" long. Tap—1 1/2 turns up.

Coils L1, L2, and L3, L4, all wound on 1 1/4" diameter formers. Provide 2 coilform holders.

*Components List for a Simple 6-volt Receiver, Fig. 19.*

L1, L2, L3, L4, sections of commercial tuning pack, such as A.I.S. Type 30A, etc. Note, padding condensers, and trimmer values are not shown, since these are included in commercial packs.

- C1, C8, 0.0005 mfd. ganged tuner.
- C2, C9, 60 mufd. ganged bandspread tuner, with Raymart MC60X tuners and couplers.

- C3, C4, C10, C11, 0.1 mfd. 350 v.w. Non-inductive.
- C12, C13, C14, C15, 0.0002 mfd. Mica.
- C18, C19, C20, 0.01 mfd. 350 v.w. Non-inductive.
- C5, 0.0001 mfd. Mica.
- C6, C7, 25 mfd. 25 v.w. Electrolytic.
- C16, C17, 8 mfd. 350 v.w. "
- C21, C23, "
- C22, "

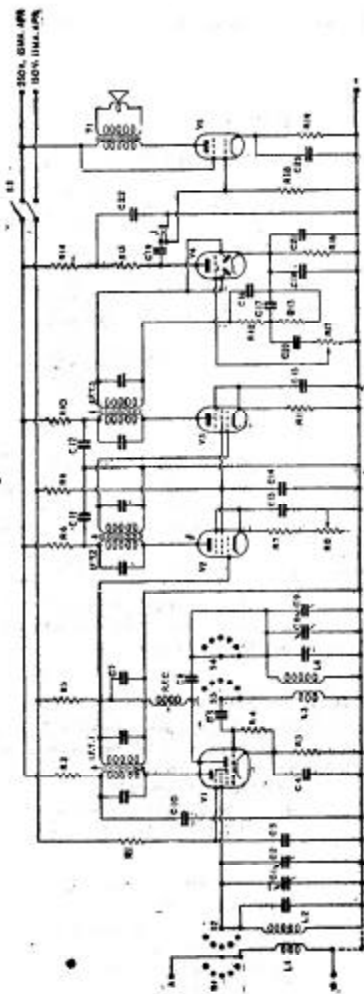

Fig. 19. A Simple 6-volt Receiver.

- |              |                                 |
|--------------|---------------------------------|
| R1,          | 10,000 ohms.                    |
| R2, R9,      | 2,200 "                         |
| R3, R7, R11, | 220 "                           |
| R4,          | 47,000 "                        |
| R5,          | 15,000 "                        |
| R6, R10,     | 1,000 "                         |
| R8,          | 5,000 ohms variable, I.F. gain. |
| R12, R15,    | 100,000 ohms.                   |
| R13,         | 470,000 "                       |
| R14,         | 22,000 "                        |
| R16,         | 3,300 "                         |
| R17,         | 1 meg. Audio gain.              |
| R18,         | 220,000 ohms.                   |
| R19,         | 430 " 1 watt.                   |
- (All resistors, except R19,  $\frac{1}{2}$  watt ratings.)
- |                |   |
|----------------|---|
| S1, 2, 3, 4,   | Wavechange switches, ganged.                          |
| S5,            | D.P.S.T. Standby switch.                              |
| J,             | Headphone jack.                                       |
| L.F.T.1, 2, 3, | 465 kcs. iron cored L.F.T.'s.                         |
| T1,            | Output transformer, 5 watt, to match 7,000 ohms load. |
- |         |       |
|---------|-------|
| V1,     | 6K8.  |
| V2, V3, | 6SK7. |
| V4,     | 6SQ7. |
| V5,     | 6F6.  |
- 5 International octal chassis mounting valveholders.  
 Chassis, aluminium, 10" x 8" x 2 $\frac{1}{2}$ ".  
 2 Tuning Drives.
- Arrange for regenerative capacity over V2.  
 No B.F.O. is included in the circuit, but may be added if required.
- Components List for an Advanced 4-volt Receiver, Fig. 20.*
- L1, L2, L3, L4, L5, L6, sections of commercial tuning pack, such as the M. Wilson 6 Waveband Coil Kit, 5-2,000 metres.
- NOTE.—Padding condensers and trimmer values are not shown, since these are included in commercial packs.
- |              |  |
|--------------|--|
| C1, C6, C13, | 0.0005 mfd. ganged tuner.  |
| C2, C7, C14, | 60 mmfd. ganged handsread tuner, with Raymart MC60X tuners and couplers. |
- |                 |                                   |
|-----------------|-----------------------------------|
| C3, C4, C5, C8, | 0.1 mfd. 350 v.w. Non-inductive.  |
| C10, C15, C16,  | 0.0002 mfd. Mica.                 |
| C17, C18, C19,  | 0.0005 mfd. Mica.                 |
| C20, C22, C26,  | 50 mmfd. Silver Mica.             |
| C28, C29, C30,  | 0.25 mfd. 350 v.w. Non-inductive. |
| C9, C11,        | 0.0001 mfd. Mica.                 |
| C12,            |                                   |
| C21,            |                                   |
| C23,            |                                   |
| C24, C25,       |                                   |

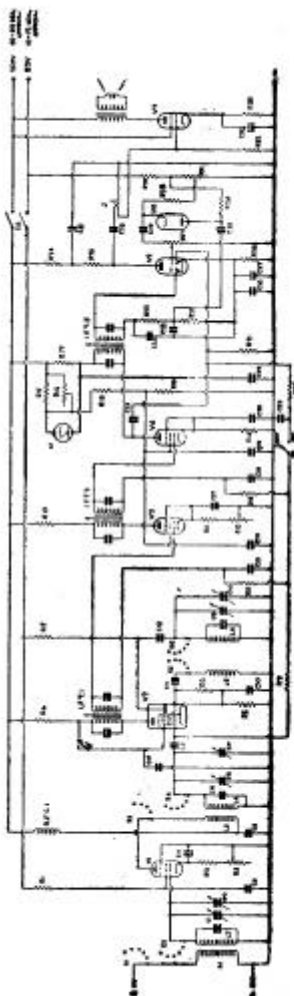

FIG. 20. An Advanced 4-volt Receiver.

50

C27, C32,	25 mfd. 25 v.w. Electrolytic.
C31,	8 mfd. 350 v.w. "
R1, R10,	1,000 ohms.
R2, R17,	220 "
R3,	5,000 ohms variable, R.F. gain.
R4, R8,	10,000 ohms.
R5, R11, R15,	330 "
R6, R24,	22,000 "
R7, R9, R13,	1 meg.
R12,	10,000 ohms, variable, I.F. gain.
R14,	470 ohms.
R16,	1,000 ohms, variable, "S" meter zero set.
R18,	6,200 ohms
R19, R30,	39,000 "
R20, R21,	680,000 "
R22,	100,000 "
R23, R28,	470,000 "
R25, R28,	47,000 "
R26,	680 "
R27,	1 meg. variable. Audio gain.
R29, R32,	220,000 ohms.
R31,	10,000 ohms variable. Noise limiter set.
R33,	180 ohms.

(All resistors,  $\frac{1}{2}$  watt ratings.)

I.F.T.1, 2, 3,	465 kcs. Iron cored I.F.T.'s.
M,	0-1 mA. meter.
J,	Headphone Jack.
R.F.C.1,	Screened all-wave choke.
S1-6,	Wavechange switch, ganged.
S7,	S.P.D.T. A.V.C. On-Off.
S8,	D.P.S.T. Standby.
T1,	Output transformer, 5 watt, to match to 5,200 ohms load.
V1,	6X4.
V2,	6AV6.
V3, V4,	6X4.
V5,	6AV6.
V6,	6X4.
V7,	Pen. 45.

1 British 7-pin chassis mounting valveholder.

5 Mazda octal " " "

1 D1 holder.

No B.F.O. is included in the circuit, but may be added if required.

Chassis, aluminium, 16" x 8" x 2 $\frac{1}{4}$ ".

2 Tuning Drives.

Arrange regenerative capacities across V1 and V3.

51



Components List for an Advanced 6-volt Receiver, Fig. 21.

L1, L2, L3, L4, L5, L6, sections of commercial tuning pack, such as the M. Wilson 6 Waveband Coil Kit, 5-2,000 metres.

NOTE.—Padding condensers and trimmer values are not shown, since these are included in commercial packs.

C1, C7, C14,	0.0005 mfd. ganged tuner.
C2, C8, C15,	60 mmfd. ganged handsread tuner, with Raymart MC60X tuners and couplers.
C3, C4, C5, C6,	0.01 mfd. 350 v.w. Non-inductive.
C9, C10, C11, C17,	0.0001 mfd. Mica.
C12, C16, C27, C28,	0.05 mfd. 350 v.w. "
C13, C18, C26,	
C19, C20, C21,	
C22, C23, C24,	
C30, C32, C33,	
C34, C38,	0.1 mfd. 350 v.w. "
C25,	50 mmfd. Silver Mica.
C29,	160 mmfd. Tuner B.F.O. set. Raymart, VC160X.
C31,	0.005 mfd. 350 v.w. Non-inductive.
C35,	0.25 mfd. 350 v.w. "
C36,	8 mfd. 350 v.w. Electrolytic.
C37, C39,	25 mfd. 25 v.w. "
R1, R7, R19,	22,000 ohms.
R2,	220 "
R3,	5,000 ohms variable R.F. gain.
R4, R12, R13,	10,000 ohms.
R17, R21, R33,	1,000 "
R5, R9, R11,	150 "
R6,	5,600 "
R8,	47,000 "
R10, R22, R25,	470 "
R14,	10,000 ohms variable I.F. gain.
R15,	4,700 ohms.
R16, R28,	390 "
R18, R30, R39,	150,000 "
R20,	39,000 "
R23,	10,000 ohms variable. Noise limiter set.
R24,	220,000 ohms.
R26, R36, R38,	100 ohms variable wirewound. " S " meter zero set.
R27,	1 meg.
R29,	680,000 ohms.
R31, R34,	1 meg. variable. Audio gain.
R32,	33,000 ohms.
R35,	2,700 "
R37,	

(All resistors,  $\frac{1}{2}$  watt ratings.)

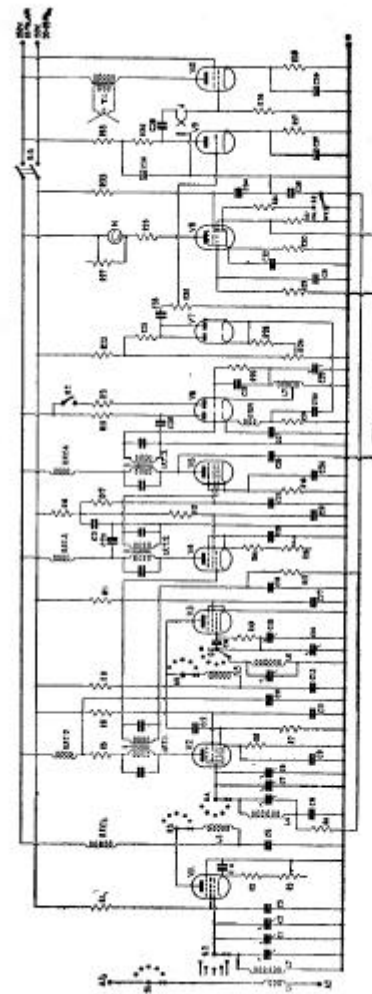

FIG. 21. An Advanced 6-volt Receiver.



L.F.T.1, 2, 3,  
R.F.C.1,  
R.F.C.2, 3, 4, 5,

M,  
J,  
S1, 2, 3, 4, 5, 6,  
S7,  
S8,  
S9,  
V1, V3,  
V2,  
V4, V5,  
V6,  
V7,  
V8,  
V9,  
V10,

465 kcs. Iron cored L.F.T.'s.  
2.5 millihenry R.F. Choke.  
Screened all wave chokes, or screened  
chokes effective at 465 kcs.  
0.1 mA. meter.  
Headphone Jack.  
Wavechange switch, ganged.  
S.P.S.T., B.F.O., On-Off.  
S.P.D.T. A.V.C. On-Off.  
D.P.D.T. Standby.  
1852 (6AC7).  
6SA7.  
6S7.  
6F8.  
6H6.  
6B8.  
6F5.  
6V6.

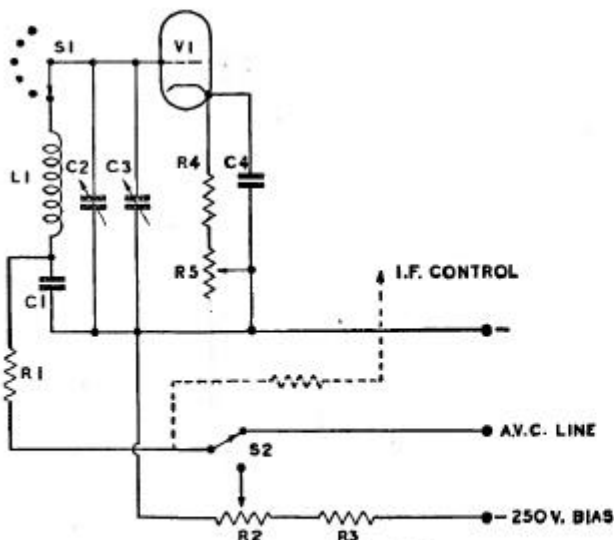

FIG. 22. Using the High Bias Line.

10 International octal chassis mounting valveholders.  
T1, Output transformer, 5 watts, to match  
8,000 ohms load.  
Chassis, aluminum, 16" x 8" x 2 1/2".  
2 Tuning Drives.  
Arrange regenerative capacities across V1 and V4.

*Components List for the High Bias Line Control of the  
R.F. Stage, Fig. 22.*

L1, First tuned circuit, R.F. stage.  
C1, 0.01 mfd. 350 v.w. Non-inductive.  
C2, C3, Sections of tuners and bandspread tuners.  
C4, 0.1 mfd. 350 v.w. Non-inductive.  
R1, 100,000 ohms.  
R2, 50,000 ohms variable, High Bias control.  
R3, 150,000 ohms.  
R4, 220 "  
R5, 5,000 ohms variable, R.F. gain.  
S1, Wavechange switch section.  
S2, S.P.D.T. A.V.C. to High Bias Switch.  
V1, R.F. valve.

NOTE.—The first I.F. stage may also be switched into the High Bias control, as shown, if a higher degree of control is required.

*Components List for a 5-metre Converter for 4 or 6 volt operation,  
Fig. 23.*

L1, 2 turns 20 S.W.G. enam. 1/2" diam., 1/4" above L2.  
L2, 6 " 16 " " 1/2" " to 1/2" long.  
L3, 10 " 16 " " 1/2" " to 1 1/4" long.  
L4, L5, Wearite PHF5, tuned to 10 mcs.  
C1, C6, 15 mmfd. tuners, Raymart VC15X.  
C2, C3, 0.01 mfd. 350 v.w. Non-inductive.  
C4, 0.0001 mfd. Mica.  
C5, C7, 3-30 mmfd, variable trimmers.

For 4-volt operation:—

R1, 10,000 ohms, 1 watt.  
R2, 33,000 "  
R3, 47,000 "  
R4, 330 "

For 6-volt operation:—

R1, 22,000 ohms, 2 watt.  
R2, 22,000 "  
R3, 47,000 "  
R4, 330 "

(Resistors, 1/2 watt ratings, unless otherwise specified.)

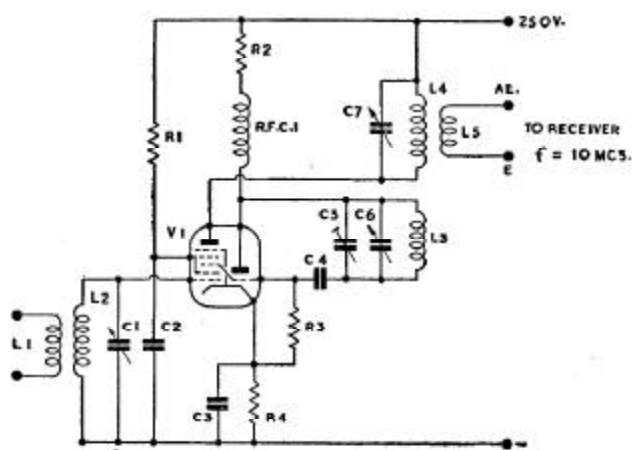

Fig. 23. A 5 metre Converter for 4 or 6 volt Operation.

- R.F.C., 60 turns 30 S.W.G. on 1 meg. ceramic resistor as former.
- V1, ACTH1 or 6K8.
- 1 British 7-pin chassis mounting valveholder, or 1 International octal chassis mounting valveholder.
- Slow-motion drive for C6, main tuning, knob drive for C1.
- Chassis, 7½" x 3½" x 2".

## CHAPTER 7 POWER SUPPLIES

The power supply for a communications receiver should be stable, capable of excellent regulation and, although not required to supply a high voltage, must be able to supply a fairly heavy current without any heating.

A good transformer is necessary to ensure proper regulation and a heavy heater winding will be required to supply all the valve heaters, especially if 4-volt valves are in use. The power pack, and therefore the whole equipment, should be protected by fuses both in the primary to mains wiring and also in the receiver supply line. The power leads to the receiver may terminate in a plug, constructed from an old octal valve base, the leads being soldered into the pins and the base then filled with Chatterton's compound or a good wax. At the receiver, the power supply may be received in an ordinary octal socket mounted at the end of the chassis, or at the rear. The power input point should be at the audio end of the receiver, bus-bar distribution through the receiver being advised.

Smooth working of the power supply is assisted by the bleeder resistance which also allows the low voltage screen feeding line to be taken out, and the adjustable bleeder should be set, with the receiver load connected to the power pack, to give the correct voltage.

A bias pack may be used with any receiver to provide a high bias line to which the R.F. amplifier may be switched for Standby or monitoring the local transmitter, or batteries may be used since the current drain is negligible and layer-built type batteries may be used, thus allowing the biasing department to be condensed to a very small size.

It may seem extravagant to give over a valve and transformer for biasing one stage, but in any case a high bias line is only required by the amateur transmitter. In the circuits showing a high bias line, this may be replaced by a simple Standby switch in the negative or positive H.T. line by the constructor who is interested only in reception. In any case, the separate heater transformer can be dispensed with if 4-volt valves are used throughout the apparatus, since in that case a spare 4-volt secondary on the main transformer can be used to supply the rectifier heater, an ordinary 4-volt rectifier being used with one section out of circuit, or strapped in parallel with the other section.

It will be seen that the bias supply has only half-wave rectification and resistance smoothing, but since only a fraction of the total voltage is used and the current is negligible the smoothing thus obtained is amply sufficient for the purpose.

Although the load of the communications receiver is steady, that is, there are no great current changes as are found in, for example, a Class B amplifier, it is thought advisable to use two-section filtering for the mains supply to give as quiet operation as possible. Where economy is necessary, however, a perfectly straightforward power supply circuit may be used with only a single L.F. choke and two condensers rather than the two chokes and three condensers shown.

A.C. power packs are shown in Figs. 24 and 25, the main difference being in the bias supply arrangements. In Fig. 24 the bias rectifier is supplied from a separate heater transformer; in Fig. 25, a power pack for 4-volt valves, the bias rectifier is supplied from a heater winding on the mains transformer. In either case the bias voltage supplies may be omitted from the circuit altogether if desired.

→ When A.C./D.C. operation is required a rather different set of circumstances arises. The use of ordinary 0.2 amp. heater valves would mean in any case that the heaters of some of the valves would be at high potentials above earth, since the number of stages in a communications receiver is, in general, higher than the number found in other receivers. The potential difference between the heater and earth increases the chance of hum as the potential rises, and thus it is desirable to keep the heater drop over the whole chain at as low a value as possible. The most promising solution would appear to be to use American 6 volt 0.3 amp. valves in all stages except the output stage, where no suitable 0.3 amp. valve is readily obtainable. In this stage, however, a British 0.2 amp. valve may be used, the heater being shunted by a suitable resistance to pass the further 100 mAs. heater current drawn by the rest of the circuit. The value of the resistance is calculated by Ohm's Law, and for one very suitable valve, the Mazda Pen 3520, whose heater operates at 35 volts 0.2 amp., the resistance across the heater would be

$$R = \frac{35}{0.1} \text{ ohms}$$

or  $R = 350$  ohms, and the resistance rating would be  $35 \times 0.1$  or 3.5 watts. Such a resistance may be made up of standard values, using a 200 ohms and a 150 ohms resistances in series, each being rated at 2 watts.

A barretter is preferable to a wire-wound dropping resistor for applying the correct potential across the heater chain, since the barretter gives a good degree of automatic compensation for changes in line voltage whilst at the same time it requires no setting to value as does the ordinary dropping resistor with an adjustable tap. Should a dropping resistor be used, however, it must be set to the correct value to give a current of 0.3 amps. through the heater chain as measured by a good A.C. or D.C. ammeter to suit the supply.

Alternatively the dropping resistor may be adjusted by measuring the voltage across the whole heater chain, the dropping resistor being adjusted until the correct voltage is shown on a good A.C. or D.C. voltmeter, the type of meter again depending on the supply.

It must be remembered that the adjustments should be made by reducing resistance—i.e., the dropping resistance should be high in value, the resistance being lowered until the valve heaters are correctly loaded. The measurements should be taken a half-minute or one minute after adjustments, since the valve heaters undergo a change of resistance with heat, as does practically any circuit.

No arrangements are shown for a high bias line in the A.C./D.C. power pack of Fig. 26, as there is no convenient way of obtaining it. If a high bias line is required, batteries must be used.

It must also be remembered that gear working from an A.C./D.C. supply is alive to the mains and the plug should be connected into the socket in such a way that the chassis of the power pack and the chassis of the receiver are both connected to the earthed mains line. In some cases it may be found that the positive line of the mains D.C. supply is earthed so that it is virtually impossible to connect the chassis of the gear to the earthed line. In this case, every precaution must be taken when using the gear, especially if it is desired to work with headphones, and the whole operating position, including the apparatus itself, should be insulated by the use of rubber mats.

In every A.C./D.C. operated receiver, not only the earthing connection to the chassis, if used, should be isolated from actual connection with the chassis by an 0.01 mfd. 500 v.w. condenser, but the aerial also should be isolated in the same manner.

The rating of the barretter or dropping resistance is of course determined by the number of valves used, together with their common current consumption and the supply voltage. For example, a circuit using 6 volt 0.3 amp. valves in an R.F. stage, a frequency converter, two I.F. stages, a detector and B.F.O. combined, an A.V.C. and "S" meter stage combined and with an audio amplifier before the output stage would have seven 6-volt valves with their heaters connected in series, the total drop thus being 6.3 volts  $\times$  7 or 44.1 volts at 0.3 amp. Then the output stage, using as recommended a Pen 3520 shunted by a 350 ohm resistance, would introduce a further drop of 35 volts at 0.3 amp., so that the total heater load would be 79.1 or 79 volts, 0.3 amp. The barretter or dropping resistance must therefore be capable of handling the heater current of 0.3 amp.

Besides the voltage across the valve heater chain, however, the rectifier also requires feeding. The 25Y5 and 25Z5 types of rectifier are in good supply at the time of writing, and are capable of supplying up to 80 mAs., which is sufficient for all but the largest receivers, these rectifiers being suitable since they also require 0.3 amp. through the heater. The 35RE, at present in very short supply, can give up to 120 mAs., and also requires a heater current of 0.3 amp., whilst the heater voltage is, as indicated by the code name, 35 volts. Presume, however, that a 25Z5 rectifier is to be used. The heater voltage of this valve must also be added to the voltage drop across the receiver heaters, so that the total heater voltage required is 79 plus 25 volts, or 104 volts.

With the usual mains voltage of 230 volts, this means that the barretter will have to drop 230–104 volts, or 126 volts. The barretter is chosen so that this figure falls as near as possible to the centre of the working range—for example, the Phillips Miniwatt type of regulator is rated at 0.3 amp., 100–240 volts for the type number 1941, so that this barretter would be perfectly suitable.

The constructor who wishes to work the receiver from a Vibrator power pack may either purchase a commercial model of pack, such as the Masteradio "Silent Surge," already mentioned, or construct his own pack using bought components.

Very careful screening and filtering must be provided, for a vibrator pack will radiate R.F. interference unless every precaution is taken. The

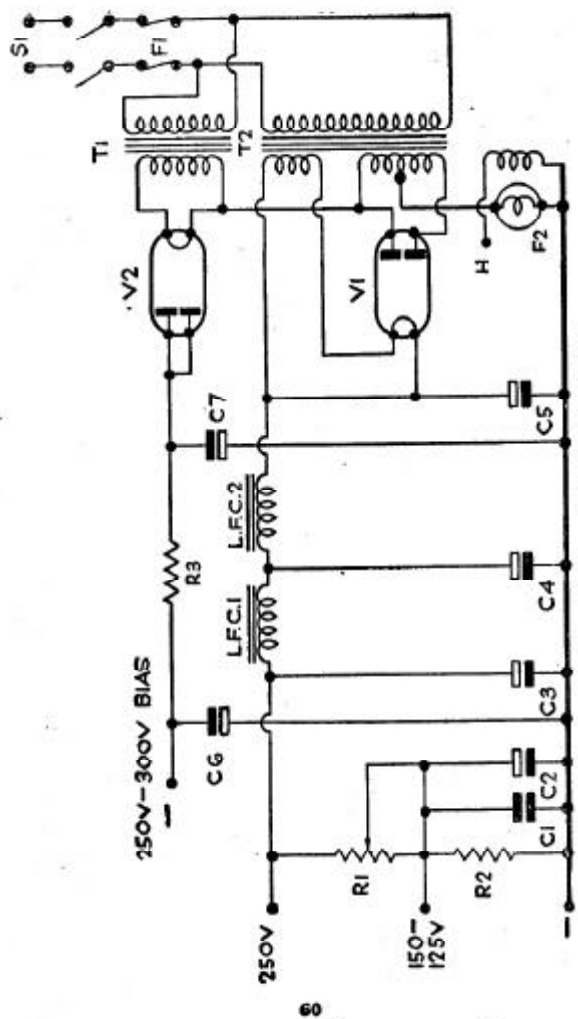

FIG. 24. A.C. Power Pack for 6-volt valves.

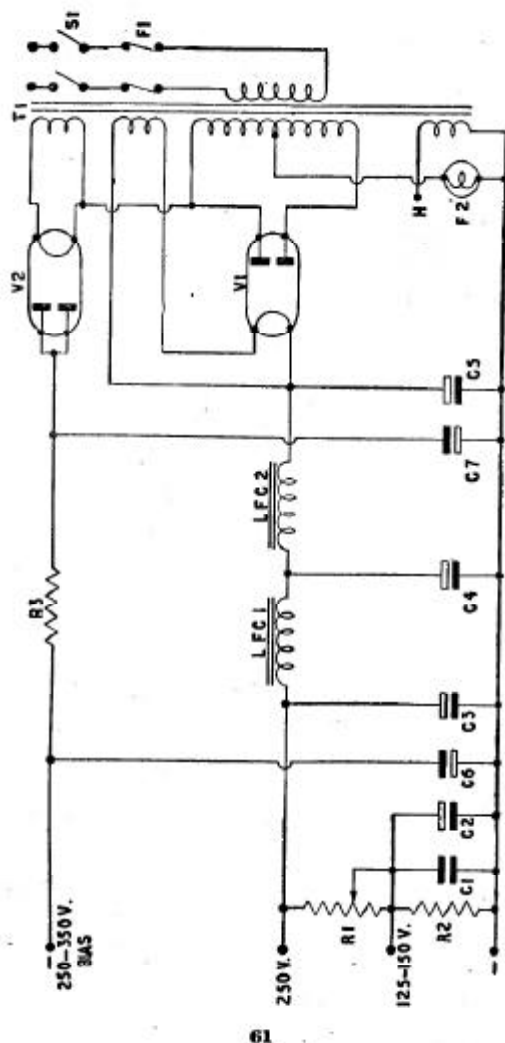

FIG. 25. A.C. Power Pack for 4-volt valves.

battery leads must be fitted with a heavy current choke in order that "hash" is not introduced into the receiver via the valve heaters, whilst the output line must be filtered for both R.F. and L.F.

Either synchronous vibrator or valve rectification may be used, and if valve rectification is decided upon it is recommended that the 0Z4 gas rectifier be used, since this valve requires no heater supply and thus not only is battery drain reduced but the chance of a breakdown obviated. The 0Z4 rectifier is at present in good supply from Government surplus stores, etc., and can supply up to 75 mAs. at 300 volts D.C. Less than 30 mAs. should not be drawn, since the valve will then work at reduced efficiency or refuse to operate properly at all.

If a current greater than 75 mAs. is required, it is advised that synchronous vibrator rectification be used.

Whilst vibrator transformers can be constructed or adapted from existing mains transformers, greater efficiency and more silent working will be obtained by using a commercial model.

The vibrator power supply must be enclosed in a metal or metal-lined box, the earth connections throughout being made with heavy gauge wire, and good quality components must be used, the working voltage values of the condensers being particularly noted. The wave shape of the currents in both primary and secondary of the vibrator transformer give rise to back E.M.F.'s sufficiently high to break down condensers of low working voltage ratings, and any breakdown or short-circuit in the power pack can cause serious damage to the vibrator.

A fuse in the supply lead to the battery is also essential, since should the vibrator contacts stick a very heavy current would flow through the vibrator and one half of the transformer primary, possibly fusing the transformer and damaging the battery. The usual fuse value used in this position is 10 amps. The switch in the battery lead should be rated at 10 amps., and should be of the Q.M.B. type.

The "hash" choke may be home-wound, using 60 or 70 turns of 16 S.W.G. enamelled copper wire (or heavier) on a 1" diameter former such as a wooden dowel.

#### Components List for the A.C. Power Packs, Figs. 24 and 25.

T1 (Fig. 24),	200-250 v. primary. 5v. 2a. secondary.
T2 (Fig. 24),	200-250 v. primary. 250-0-250 v. 200 mAs. secondary. 6 v. 4 a. 5 v. 2 a.
T1 (Fig. 25),	200-250 v. primary. 250-0-250 v. 200 mAs. secondary. 4 v. 2 a. 4 v. 2 a. 4 v. 8 a.
L.F.C. 1, 2,	20 Hys. 200 mAs. 150 ohms.
C1,	0.1 mfd. 350 v.w. Non-inductive.
C2, C4, C6,	8 mfd. 350 v.w. Electrolytic.
C3,	16 mfd. 350 v.w. "
C5, C7,	8 mfd. 500 v.w. "

62

R1,	10,000 ohms, 3 watts, with slider
R2,	22,000 " 1 "
R3,	10,000 " 1 "
F1,	5 amps. fuses.
F2,	200 mAs. fusebulb with holder.
S1,	D.P. On-Off Switch.
V1, V2 (Fig. 24),	5Y3C.
V1, V2 (Fig. 25),	UU6.
2 International or Mazda octal chassis mounting valveholders. Chassis, 9½" x 4½" x 2", aluminium.	

#### Components List for the A.C./D.C. Power Pack, Fig. 26.

L.F.C. 1, 2,	20 Hys. 100 mAs. 150 ohms.
R1,	5,000 ohms, 3 watts, with slider.
R2,	22,000 " 1 "
C1,	0.1 mfd. 350 v.w. Non-inductive.
C2, C4,	8 mfd. 350 v.w. Electrolytic.
C3,	16 mfd. 350 v.w. "
C5,	8 mfd. 500 v.w. "
V1,	25Y5, 25Z5, 35RE, etc.
B,	Barretter to suit heater load.
1 International octal chassis mounting valveholder. 1 Holder for Barretter used.	
F,	1 amp. fuses.
S1,	D.P. On-Off Switch.
Chassis, 9½" x 4½" x 2", aluminium.	

#### Components List for the Vibrator Power Packs, Figs. 27 and 28.

T1,	Vibrator transformer, Bulgin M.T.5, or similar.
R1, R2,	220 ohms, 1 watt.
R3,	4,700 " 1 "
R4,	To suit screen current. (See Note.)
C1,	0.5 mfd. 350 v.w. Non-inductive.
C2,	0.0003 mfd. Mica.
C3,	0.01 mfd. 1,500 v.w.
C4,	0.01 mfd. 350 v.w. Non-inductive.
C5, C7,	8 mfd. 350 v.w. Electrolytic.
C6,	16 mfd. 350 v.w. "
C8,	0.1 mfd. 350 v.w. Non-inductive.
R.F.C. 1,	Hash filter. (See text.)
R.F.C. 2,	Screened all-wave choke.
L.F.C.,	20 Hys. 100 mAs. 150 ohms.
F,	10 amp. fuse.

63

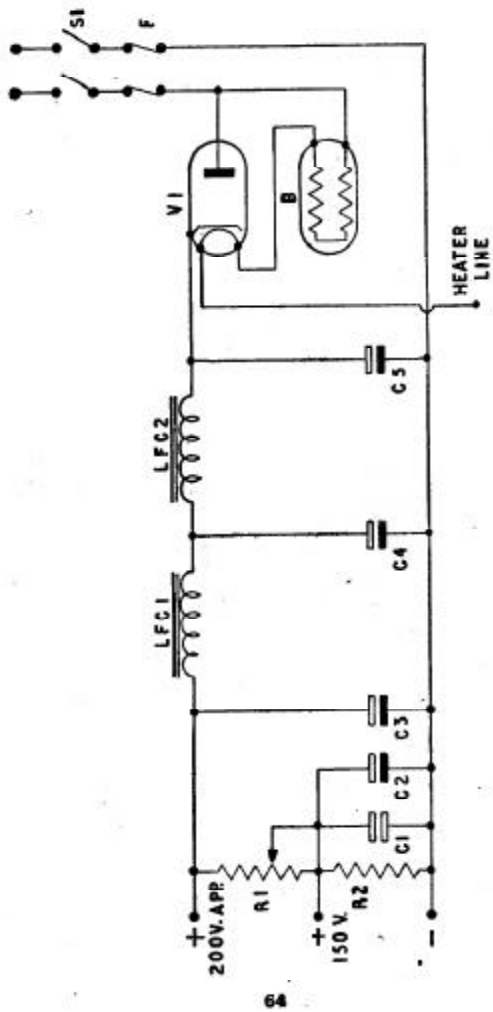

Fig. 26. A.C./D.C. Power Pack.

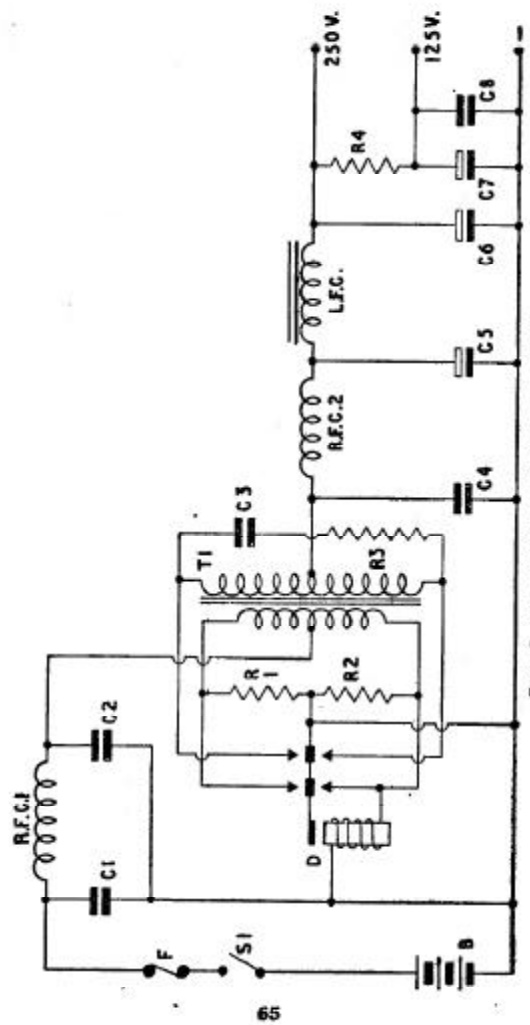

Fig. 27. Vibrator Pack with Valve Rectification.

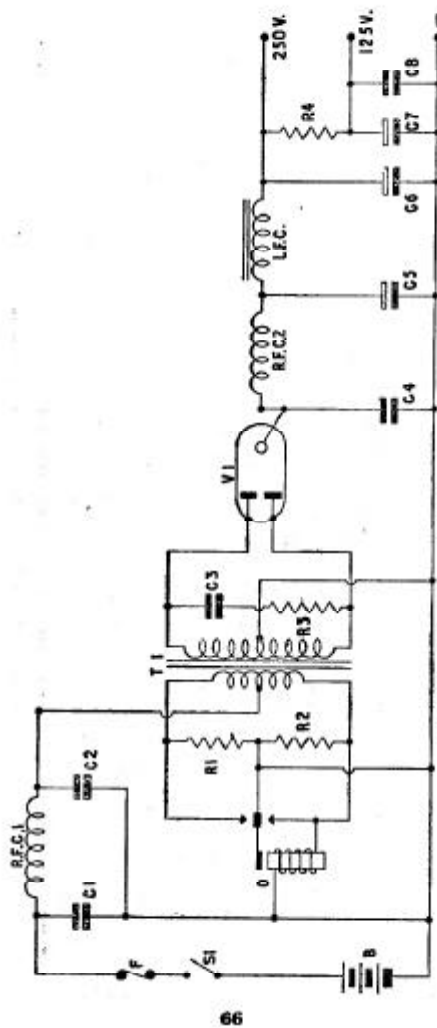

FIG. 28. Vibrator Pack with Synchronous Rectification.

- S1, Q.M.E. On-Off Switch.  
 B, 6-volt accumulator battery.  
 D, Vibrator driving coil.  
 V1 (Fig. 27), OZ4.  
 1 International octal chassis mounting valveholder for V1.  
 Chassis and shielding cover.

NOTE.—The constructor should follow any makers' instructions obtained with the vibrator, particularly as regards buffering circuits. It may be desirable, for instance, either to shunt R1 and R2 with 0.1 mfd. condensers, or to replace the resistances altogether by such condensers.

It is possible to obtain a reversed polarity at the output side, so that no output filter component should be connected up, especially C5, C6 and C7, the electrolytic condensers, until the output polarity has been checked. This, of course, refers to Fig. 27.

A dropping resistance rather than a potential divider is used for the screen supply to avoid further current drain. The resistance R4 should be chosen to give the correct voltage drop at the current passing, using a simple calculation by Ohm's Law. Each circuit diagram in the previous chapter shows the approximate screen current on the 150-volt line.

This method may also be used, if desired, in the A.C. and A.C./D.C. power packs.

## CHAPTER 8

### AERIALS FOR COMMUNICATIONS

It is, of course, impossible to give anything like a full account of aerial theory and practice in a few pages, but some salient points can be noted especially for the use of the receiving amateur. The transmitting amateur will in all probability use the one aerial for transmission and reception except for Duplex and Break-in working, which means that the aerial and its coupling to both transmitter and receiver will be adjusted to the band in use and will thus be working at maximum efficiency at all times.

The transmitting aerial, as has already been noted, is usually the best receiving aerial, but where the communications receiver is to be used alone, in a listening post, then the most useful aerial is that which will receive all amateur bands as well as broadcast and commercial stations with as great efficiency as possible.

The reader who requires further information on aerials and their many types is referred to the Aerial Handbook, No. 56, in Bernard's List.

At high frequencies—that is, for short-wave reception—a tuned aerial can be erected in quite a small space. The best example is perhaps the television aerial, seen in ever greater numbers at the top of flagstaves and attached to chimneys. This type of aerial is a vertical half-wave, and often has a reflector so situated that the true aerial is in line with transmitter and reflector, the reflector, naturally, being behind the aerial.

The half-wave aerial, as its name suggests, is a half-wavelength long, measured electrically rather than mechanically. An aerial suffers from what is known as the "end effect" so that a half-wave aerial is slightly shorter than a measured half-wave, the relationship being given by the formula

$$L = \frac{462}{f}$$

where  $L$  is the total length of the aerial in feet and  $f$  is the operating frequency in megacycles. The formula can also be given as

$$Ll = \frac{5540}{f}$$

where  $Ll$  is the aerial length in inches.

To take an example, a television aerial for vision reception must work with maximum efficiency at 45 mcs., so that the aerial length is

$$Ll = \frac{5540}{45}$$

or  $Ll = 123.1$  inches or  $10' 3''$ .

The television aerial is mounted vertically since the transmitter aeri- als are also vertical, and the transmitted waves are therefore said to be vertically polarised. This polarisation holds only over relatively short distances, however, so that for general working on rather lower frequencies the great majority of aeri- als are horizontal. The increased length of an aerial for lower frequencies also makes horizontal construction simpler, although the new B.B.C. vertical long-wave aerial may be cited as an example of vertical polarisation on the very low frequency band.

By erecting an aerial tuned to the frequency of operation the signal strength is increased at the receiver and, at the transmitter, the aerial accepts all the power which can be passed to it.

For working on the 20 and 40 metre amateur bands the half-wave aerial is still sufficiently short for erection in a fairly small space, but it is practically impossible to erect a tuned aerial for, say, the broadcast transmissions at medium frequencies, and in any case such an aerial would be larger than the licence allows.

For wide frequency coverage, therefore, a compromise must be made. The aerial in any case will be more efficient at the higher frequencies which is where the efficiency is needed, so that the best arrangement is that which will give good working on all the amateur bands, the lower frequencies being left to take their chance.

The direction in which the aerial receives most efficiently also requires consideration. The half-wave aerial, at whatever frequency for which it is built, receives most strongly from a direction at right-angles to the plane of the aerial wire, and is thus known as a broadside radiator or receiver. Reception of stations in line or nearly so with the wire will, other things being equal, be much weaker than reception from stations in a direction perpendicular to the wire. For this reason, 5 and 10 metre transmitters often arrange their aeri- als to be rotating, so that the array can be turned bodily to direct the signal to any required compass point.

By erecting an aerial known as a "long wire," however, the "end fire" effect—that is, the strength of transmission or reception in line or nearly so with the aerial wire itself is greatly improved, whilst the broadside radiation or reception is attenuated. In general, however, a wire twice the wavelength of the favoured band in length will give good all-round coverage in the British Isles if erected in a due East-West direction.

The formula for the length of a two-wavelength aerial, or for any aerial longer than a half-wave, is

$$L = \frac{492(n-0.05)}{f} \text{ feet}$$

where  $L$  is the length of the aerial wire in feet,  $n$  is the number of half-waves in the aerial length, and  $f$  is the favoured operating frequency in mcs. Thus, as an example, if the favoured band is the 20 metre amateur band, the frequency in this case being taken as 14 mcs., the two-wavelength aerial will contain four half-waves. The formula then becomes

$$L = \frac{492(3.95)}{14}$$

$$\text{or } L = 138.8 \text{ feet.}$$

It is still necessary to connect the aerial to the receiver, and the best method to use with a long wire aerial is to cut the aerial at the exact centre, supporting the cut ends by a short insulator of strength sufficient to carry the strain of the aerial. The wire is thus separated into two equal portions in line one with the other.

All aeri- als have a radiation resistance, or characteristic resistance presented to a feeder system at their points of maximum current (current anti-nodes). Resistance of a four half-wave aerial is approximately 110 ohms, though this resistance changes within fairly narrow limits with the height of the aerial and the type of ground at the locality. The feeder requires matching to this aerial resistance and also to the receiver, and so a suitable type of feeder must be chosen and matched to the receiver, for best results, through a circuit such as that shown in Fig. 3, although the feeder may be taken directly to the receiver with a slight loss of efficiency.

The use of a 110 ohm feeder will allow the connection to be made, at the aerial end, directly to any current anti-node (these occur at every odd quarter of a wavelength along its length), that is, in a two wavelength aerial at points along its length equal to  $\frac{1}{4}$ ,  $\frac{3}{4}$ ,  $\frac{5}{4}$  and  $\frac{7}{4}$  of the total length. The aerial may be cut at any of these points and 110 ohm feeders connected.

Such a feeder may be purchased, and the mismatch will not be serious if 80 ohm feeder is used. Several makers can supply such feeder and ordinary lighting flex presents approximately the correct characteristics, although such a feeder would not weather well.

In a situation where bad interference is experienced, another type of feeder may be required, where twin wires are lashed to transposition blocks at every 18" or so, such blocks being obtainable from Messrs. Eddystone or Raymarts. The feeder wires are thus crossed at regular intervals, the effect being to cancel out any signal, including interference, which is picked up by



the feeders themselves. A matching unit should be used between such a feeder and the receiver.

In very noisy localities, with interference from traffic, neon signs, and the like, a short aerial may prove better than a properly-designed long aerial, since the signal-to-noise ratio must be kept high for satisfactory reception. In this case, the aerial can only be decided upon by experiment, and it may prove beneficial to use a complete commercial aerial system such as the "Eliminnoise."

#### APPENDIX

##### Coil pack Manufacturers and Distributors :—

Aligned Instrument Services, 1, Colworth Road, Leytonstone, E.11.  
(Type 30 series coil packs.)

M. Wilson, Ltd., 307, High Holborn, London, W.C.1.

##### Raymart and Eddystone Depots :—

Radiomart, 48, Holloway Head, Birmingham 1.

Webb's Radio, 14, Soho Street, London, W.1.

##### Crystal Manufacturers :—

The Quartz Crystal Co., Ltd., 63-71, Kingston Road, New Malden, Surrey.

##### Valve Stockists :—

J. Bull & Sons, 246, High Street, Harlesden, London, N.W.10.

Tele-Radio (1943), Ltd., 177A, Edgware Road, London, W.2.